

Service Manual

MusicBank CD Player System

DRAGON-CD/DAC Limited

CONTENTS

[DRAGON-CD Limited — CD Player Unit]

1. General	1-2
2. Mechanism Ass'y and Parts List	1-4
2.1. Synthesis	1-4
2.2. Front Panel Ass'y (A01)	1-6
2.3. Rear Panel Ass'y (A02)	1-7
2.4. Mechanism Deck Ass'y (A03)	1-8
2.5. Tray Ass'y (B01)	1-10
2.6. Side Chassis R Section (B02)	1-11
2.7. Main Chassis Section (B03)	1-12
2.8. Drive Unit CA Section (B04)	1-13
3. Modified Circuit	1-14

[DRAGON-PS Limited — Power Supply Unit]

1. Mechanism Ass'y and Parts List	2-2
1.1. Synthesis	2-2
1.2. Front Panel Ass'y (A01)	2-3
2. Remote Control Unit	2-4

[DRAGON-DAC Limited]

1. General	3-2
2. Parts Location for Electrical Adjustment	3-4
3. Electrical Adjustments	3-4
4. Mechanism Ass'y and Parts List	3-5
4.1. Synthesis	3-5
4.2. Front Panel Ass'y (A01)	3-7
4.3. Rear Panel Ass'y (A02)	3-8
5. Mounting Diagrams and Parts List	3-9
5.1. DIF D-D P.C.B. Ass'y	3-9
5.2. DAC FA P.C.B. Ass'y	3-10
6. IC Block Diagrams	3-13
7. Block Diagram	3-15
8. Specifications	3-16

Schematic Diagram for DRAGON-DAC Limited (See the end of this manual.)

This service manual consists of the following units.

- DRAGON-CD Limited (CD Player Unit)
- DRAGON-PS Limited (Power Supply Unit)
- DRAGON-DAC Limited (DAC)

Note:

This RAGON-CD/DAC Limited Service Manual describes the different items from the DRAGON-CD/DAC (0Q06188A) issued on April, 1995. For items other than described in this Service Manual, please refer to the RAGON-CD/DAC Service Manual.

**DRAGON-CD Limited
(CD Player Unit)**

MusicBank CD Player

DRAGON-CD Limited CD Player Unit

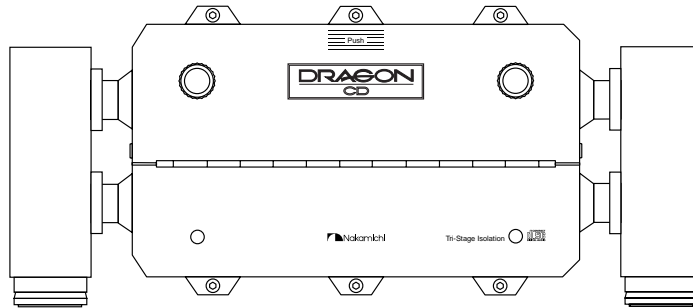

CONTENTS

- 1. General 1-2**
- 2. Mechanism Ass'y and Parts List 1-4**
 - 2.1. Synthesis 1-4
 - 2.2. Front Panel Ass'y (A01) 1-6
 - 2.3. Rear Panel Ass'y (A02) 1-7
 - 2.4. Mechanism Deck Ass'y (A03) 1-8
 - 2.5. Tray Ass'y (B01) 1-10
 - 2.6. Side Chassis R Section (B02) 1-11
 - 2.7. Main Chassis Section (B03) 1-12
 - 2.8. Drive Unit CA Section (B04) 1-13
- 3. Modified Circuit 1-14**

1. GENERAL

1.1. Product Code
V686

1.2. Destinations
USA, CAN, OTR, EP, JPN

- Abbreviations
- USA — U.S.A.
 - CAN — Canada
 - OTR — Other
 - EP — Europe
 - JPN — Japan

1.3. Package Ass'y and Accessory Ass'y

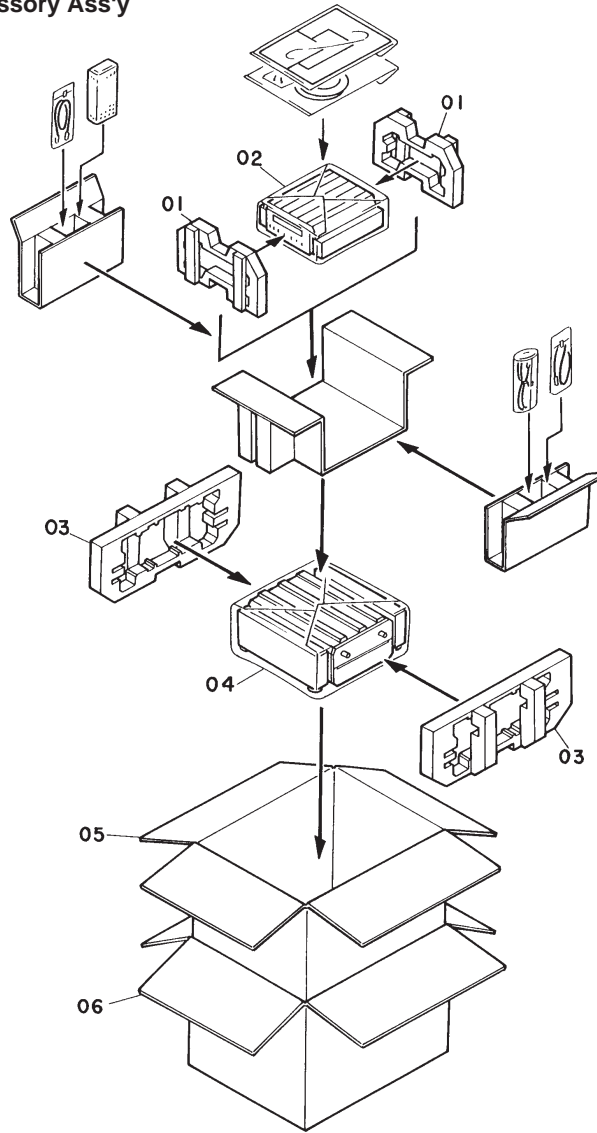

Fig. 1

Schematic Ref. No.	Part No.	Description	Q'ty	Schematic Ref. No.	Part No.	Description	Q'ty
		Package Ass'y				Accessory Ass'y	1
01	0F05006A	Packing (for Power Supply Unit)	2	0B80864A	AC Cord 2P Socket (USA, CAN)		1
02	0F04874A	Soft Sheet A (for Power Supply Unit)	1	0B80826A	AC Cord 2P Socket (JPN, OTR, EP) (for Power Supply Unit)		1
03	0F05002A	Packing F,R (for CD Player Unit)	2	0B80827A	NC 3 Cable Ass'y (for Power Supply Unit)		1
04	0F04956A	Soft Sheet (for CD Player Unit)	1	0C09816B	Adaptor 3-Inch		7
05	0F05001A	Inner Carton	1	0D06703A	DIN Cord (for Power Supply Unit)		1
06	0F05009A	Outer Carton	1	0D06717A	CD Cloth		1
				0F04931A	Soft Sheet		1
				—	Remote Control Unit		1
				DG05497A	Owner's Manual (Japanese)		1
				DG05498A	Owner's Manual (English)		1
				DG05515A	Owner's Manual (English/German/French)		1
				DG05012A	Information Ass'y (Japanese)		1
				DG05014A	Information Ass'y (English)		1
				DG05501A	Technical Information Ass'y (Japanese)		1
				DG05502A	Technical Information Ass'y (English)		1
				DG05516A	Technical Information Ass'y (English/German/French)		1
				0E03310A	M4x6 + Binding (Black)		4
				0J04310A	Washer Poly Slider FT-40		4

2. MECHANISM ASS'Y AND PARTS LIST

2.1. Synthesis

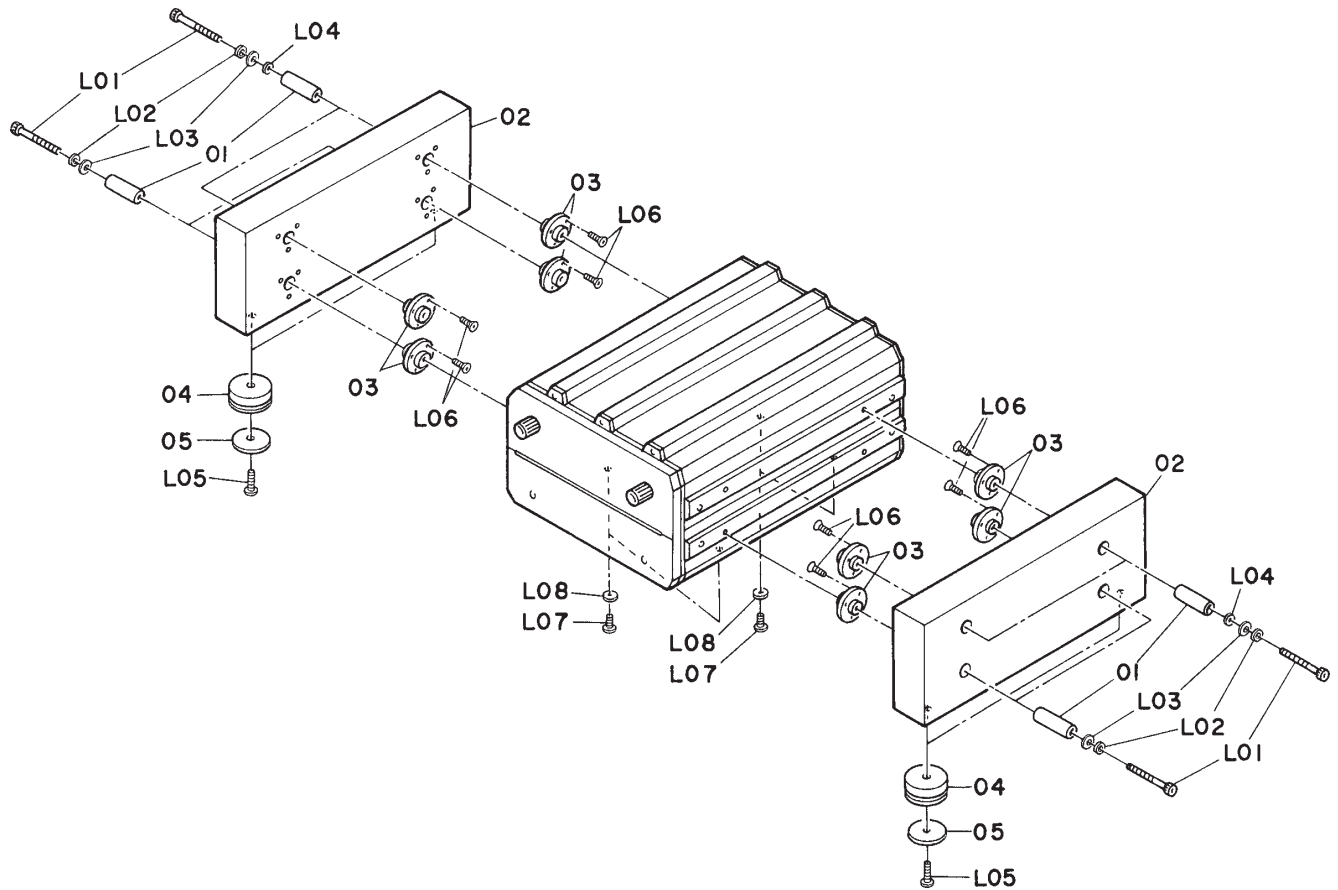

Fig. 2.1.1 Synthesis (1/2)

2.1. Synthesis

Schematic Ref. No.	Part No.	Description	Q'ty	Schematic Ref. No.	Part No.	Description	Q'ty
Synthesis				30	OJ07486A	Mecha Cushion	2
				31	OJ07456A	Seal S	2
01	OJ07542B	Sleeve	8	32	OJ07601A	AL Stabilizer Bottom	1
02	0H07021A	Side Wood Plate	2	33	0H07020B	Bonnet Lower	1
03	0H07024A	Side Spacer A	8	34	0H08608A	Emblem	1
04	0H07023A	Leg	4	L01	0E03889A	M5x50 Hex. Bolt	
05	OJ07543A	Leg Cushion	4	L02	0E03883A	Washer 5.5x10x0.8 (Black)	
06	0H07014B	Bonnet Upper	1	L03	0E00819A	Spring Washer 5mm	
07	OJ07481B	Collar	8	L04	OJ07593A	Washer Poly Slider 5mm	
08	OJ07507A	Al Stabilizer Upper	1	L05	0E03872A	TP4x20 + Pan (Black)	
09	—	Rear Panel Ass'y	1	L06	0E03901A	TP3x18 + Countersunk (Black)	
10	BA09409A	Main P.C.B. Ass'y	1	L07	0E03853A	Shipping Lock Screw	
11	—	Front Panel Ass'y	1	L08	OJ04310A	Washer Poly Slider FT-40	
12	BA09210A	Tilt Switch P.C.B. Ass'y	1	L09	0E03866A	ST3x17 Button Bolt (Black)	
13	0B80685A	3P Connector Ass'y CN107	1	L10	0E00857A	BT3x6 + Binding	
14	OJ07540B	Channel	2	L11	0E03030A	M3x6 + Binding	
15	OJ07285A	Cushion Channel	2	L12	0E00800A	ST3x6 + Binding	
16	CG09331A	Mechanism Deck Ass'y	1	L13	0E04207A	M4x10 Button Bolt (Gold)	
17	0H07026A	Lid	1	L14	OJ07594A	Washer Poly Slider 4mm	
18	0B80671A	12P Connector Ass'y CN104	1	L15	0E00818A	M3x8 + Binding (Black)	
19	0B80672A	4P Connector Ass'y CN105	1	L16	0E03769A	PT2.6x8 + Binding	
20	0B80670B	6P Connector Ass'y CN103	1	L17	0E03900A	M3x5 Hex. FH (Black)	
21	OJ07539B	Sub Chassis	2	L18	0E03746A	M3x6 Countersunk	
22	OJ07538A	Damper	4	L19	0E03805A	PT3x9.5 Special Screw	
23	3J07491A	Damper SL R	2	L20	OJ07534A	Insulator	
24	3J07490A	Damper Holder R	2	L21	0E03815A	PT3x12 + Flat Head	
25	3J07489A	Damper Holder F	2				
26	3J07492A	Damper SL F	2				
27	OJ07352A	Spring Sus Front	2				
28	JG04906A	Main Chassis Ass'y	1				
29	OJ07260A	Spring Sus Rear	2				

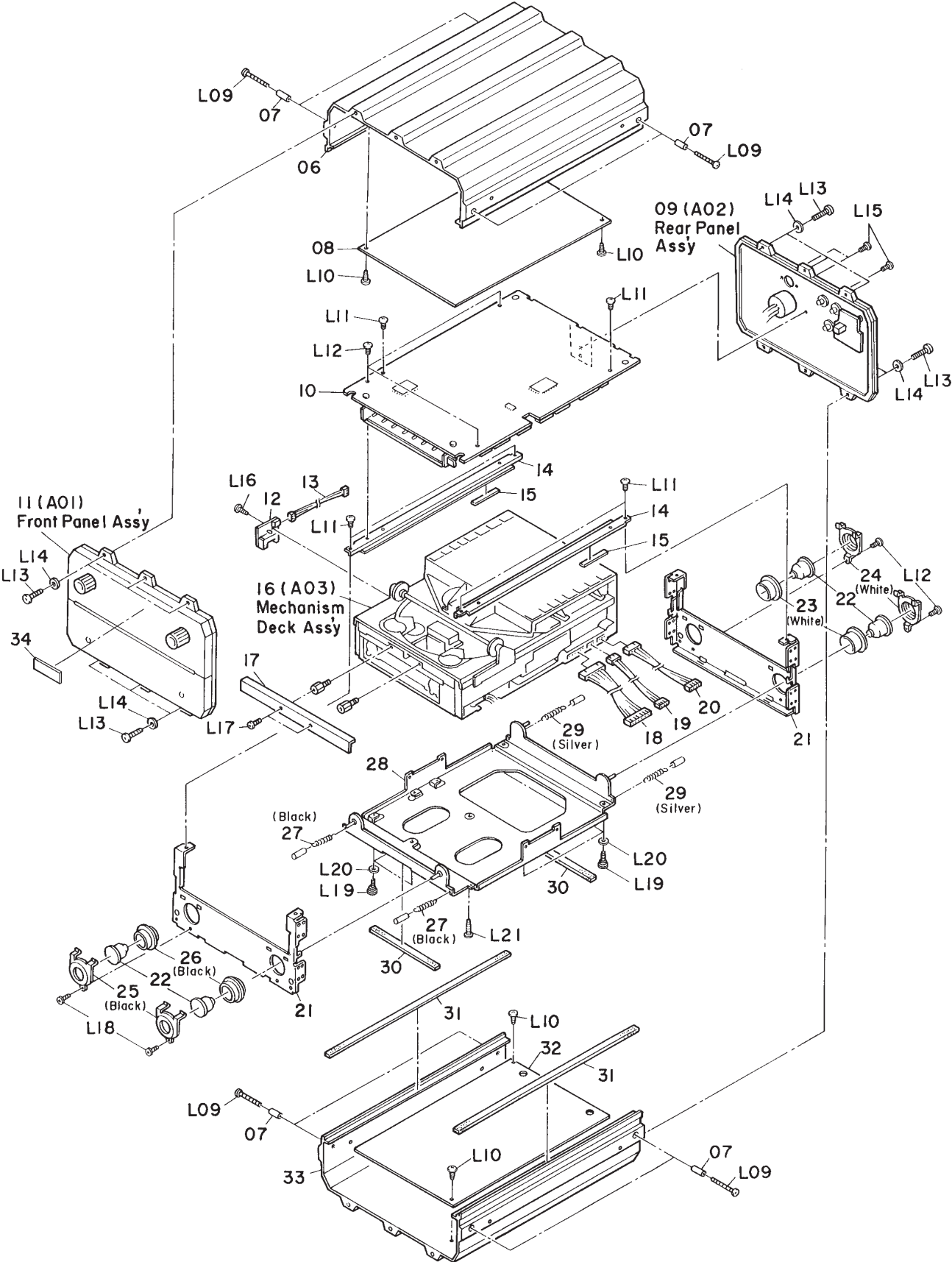

Fig. 2.1.2 Synthesis (2/2)

2.2. Front Panel Ass'y (A01)

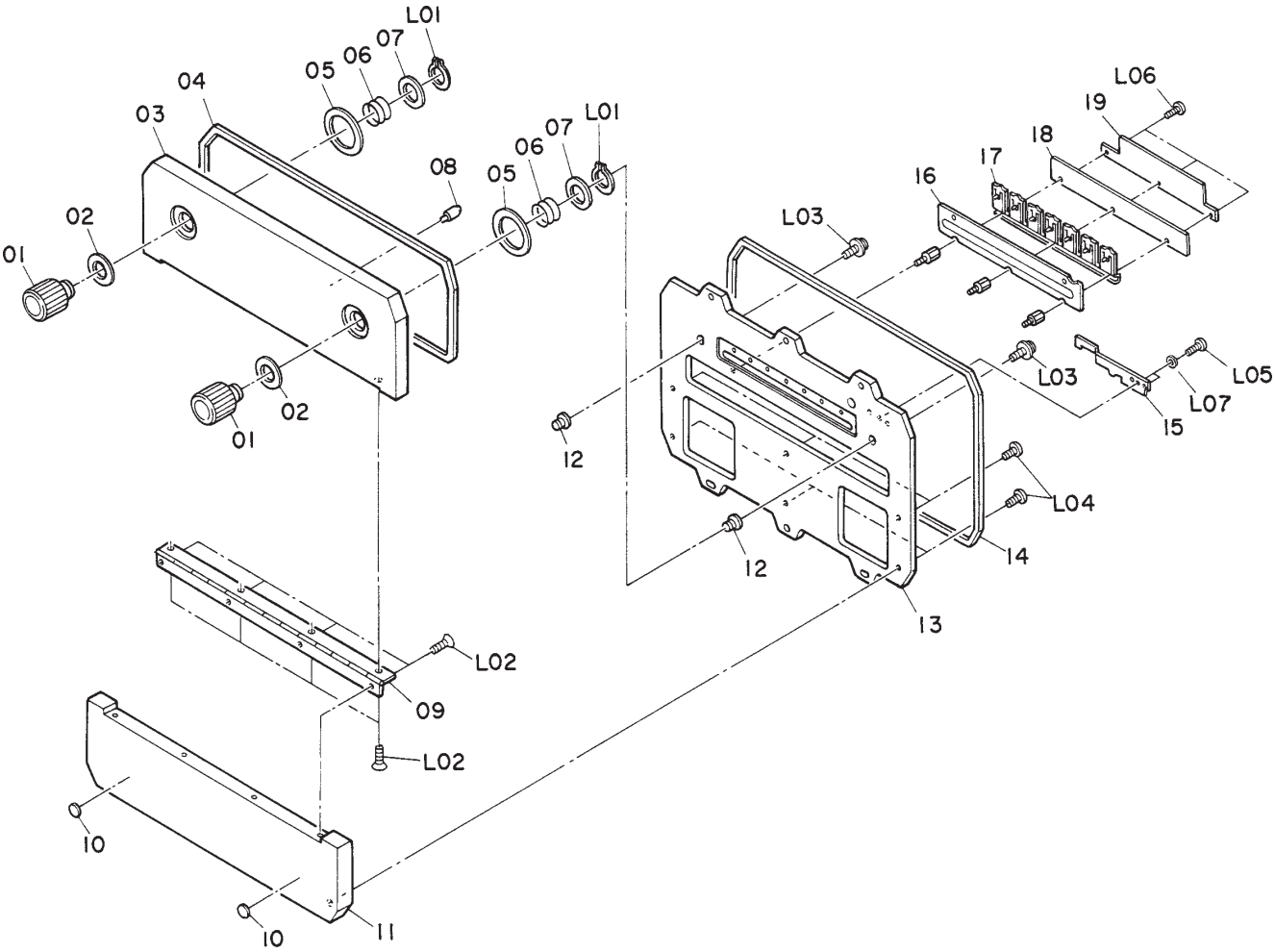

Fig. 2.2

2.2. Front Panel Ass'y (A01)

Schematic Ref. No.	Part No.	Description	Q'ty	Schematic Ref. No.	Part No.	Description	Q'ty
A01	—	Front Panel Ass'y	1	16	HA07021B	Indicator Ass'y	1
01	0H08620A	Knob Ass'y	2	17	0H06770C	Button Disc	1
02	0J07595A	Washer 12.2mm	2	18	0J07325B	Diffusion Sheet	1
03	0H08609A	Front Door	1	19	0J07579A	Diffusion Sheet (Gray)	1
04	0H06935B	Door Sponge	1	L01	0E03851A	C Stopper	
05	0H07092A	Door Spacer	2	L02	0E03867A	M2.6x5 + Pan	
06	0J07495A	Spring K	2	L03	0E03850A	M2.6x5 + Binding 3A (Black)	
07	0J07485A	Knob Spacer B	2	L04	0E00896A	M3x6 + Binding	
08	0H06954A	Door Pin	1	L05	0E03243A	M2x2.5 + Pan	
09	0H08607A	Door Hinge	1	L06	0E03529A	M2x4 + Binding	
10	0H06955A	Cushion D	2	L07	0J07612A	Washer 4x2.1x0.5	
11	0H07017A	Door Base	1				
12	0J07484C	Lock Stud	2				
13	0H07012A	Front Panel	1				
14	0H07088A	Front Shield	1				
15	0J07503C	Door Switch Sheet	1				

2.3. Rear Panel Ass'y (A02)

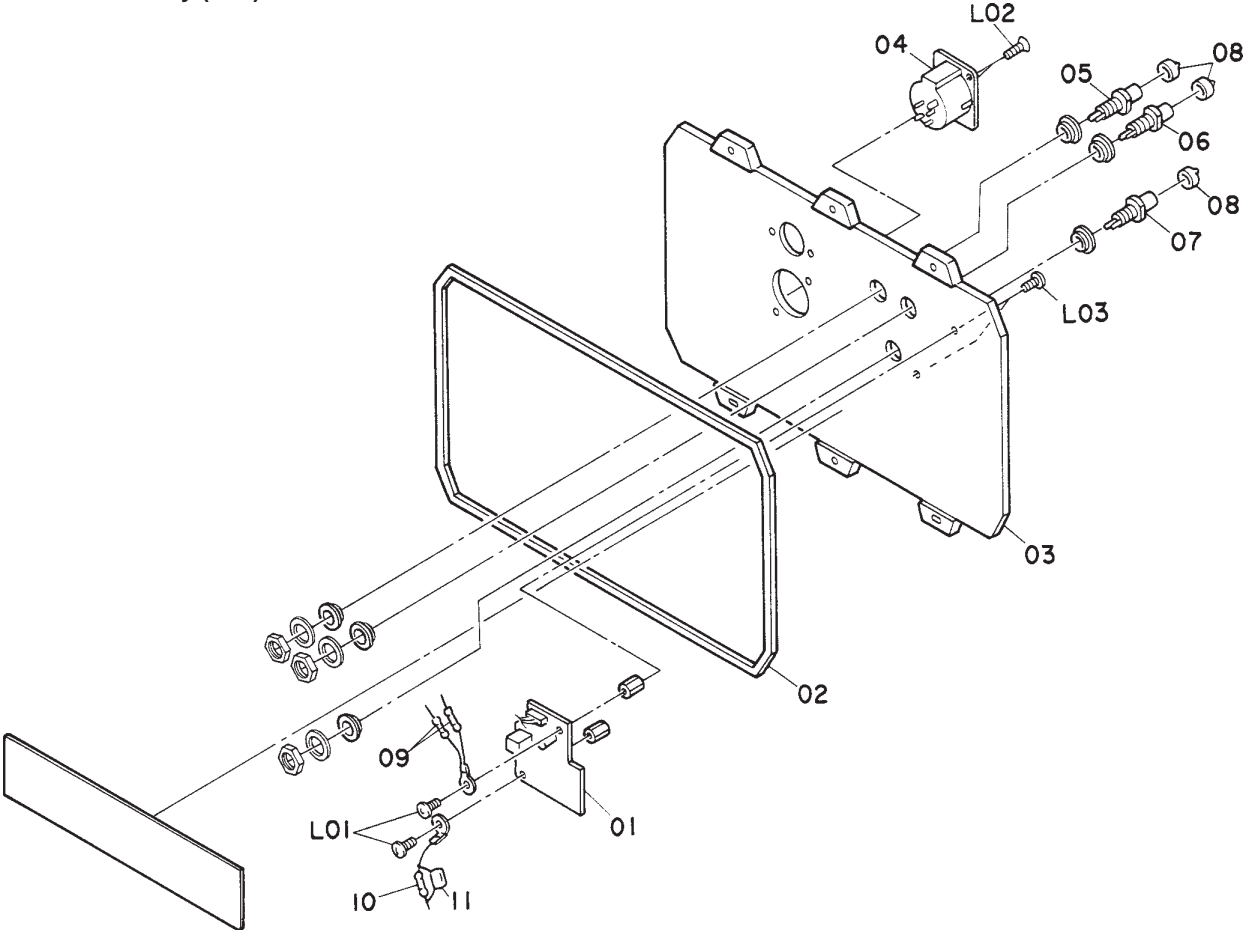
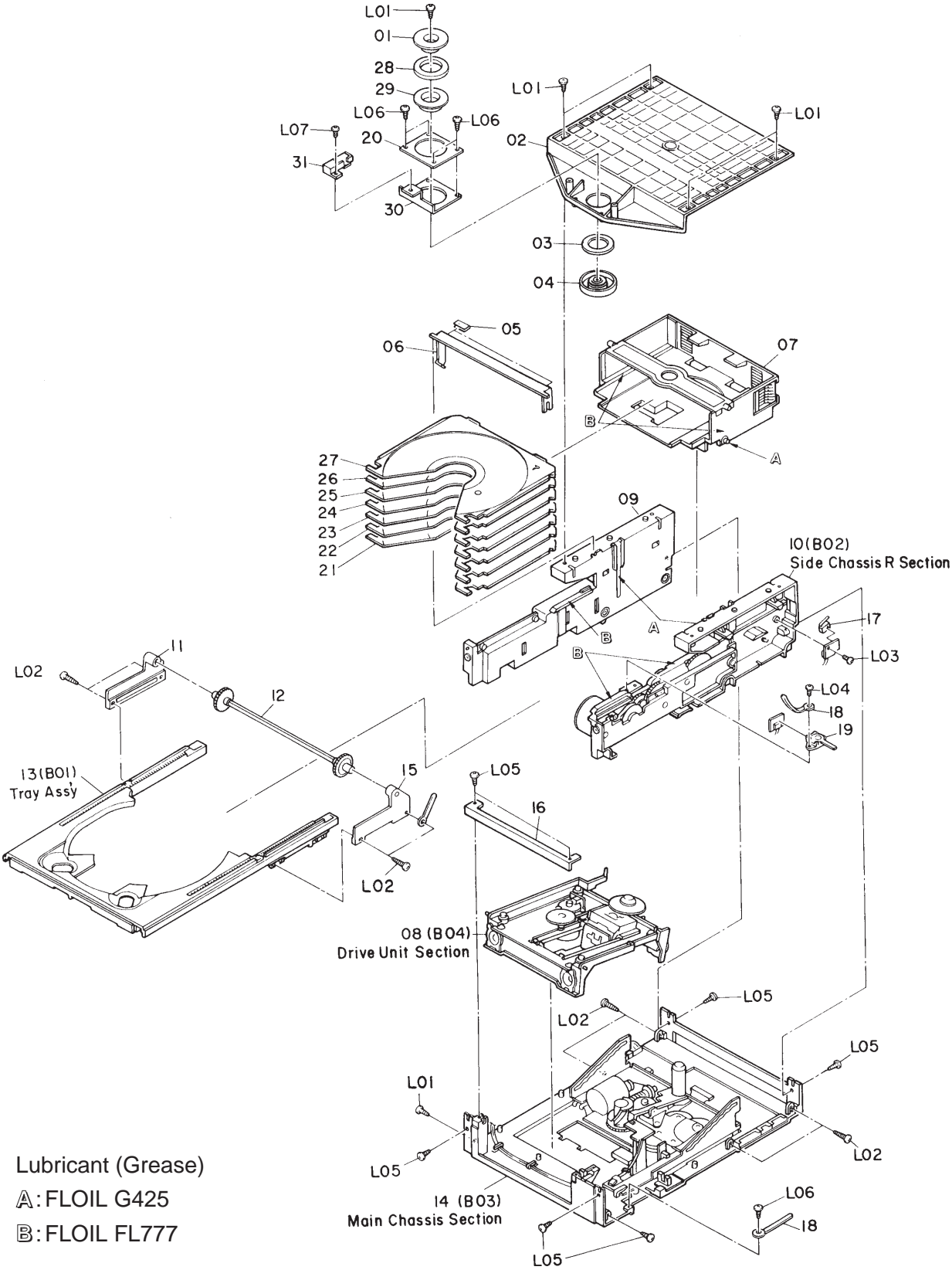

Fig. 2.3

2.3. Rear Panel Ass'y (A02)

Schematic			
Ref. No.	Part No.	Description	Q'ty
A02	—	Rear Panel Ass'y	1
01	BA09410A	Digital Out P.C.B. Ass'y	1
02	0H07088A	Front Shield	1
03	0H07013A	Rear Panel	1
04	0B80830A	3P XLR Connector (Male) [PJ803]	1
05	0B80828A	1P Pin Jack (WHT) [PJ801]	1
06	0B80862A	1P Pin Jack (RED) [PJ802]	1
07	0B80863A	1P Pin Jack (YEL) [PJ301]	1
08	0B84524A	RCA Cap	3
09	0B22666A	RM 10 1/4W F [R561L,R]	2
10	0B22567A	RM 100 1/4W F [R560]	1
11	0B41823A	CML 0.01 50V J [C560]	1
L01	0E00964A	M3x5 + Binding	
L02	0E03905A	ST3x6 + Countersunk (Black)	
L03	0E00985A	M3x6 + Binding (Black)	

2.4. Mechanism Deck Ass'y (A03)



Lubricant (Grease)
 A: FLOIL G425
 B: FLOIL FL777

Fig. 2.4

2.4. Mechanism Deck Ass'y (A03)

Schematic Ref. No.	Part No.	Description	Q'ty
A03	CG09331A	Mechanism Deck Ass'y	1
01	2C00128A	Clamper Top MSS	1
02	2C00285A	Top Cover N	1
03	2C00016A	Magnet 17x27x5	1
04	2C00015A	Clamper LO	1
05	2C00101A	A Arm Cushion	2
06	2C00116A	Assist Arm N	1
07	CB00245A	Stocker N Ass'y	1
08	—	Drive Unit CA Section	1
09	2C00284A	Side Chassis L N	1
10	—	Side Chassis R N Section	1
11	2C00098A	Tray Holder L	1
12	CB00230A	Timing Ass'y	1
13	CB00246A	Tray Ass'y N	1
14	—	Main Chassis N Ass'y	1
15	2C00097A	Tray Holder R	1
16	0C09857A	Mecha B Stopper BLK	1
17	2B70009A	Store Switch MSS-10L2-1	1
18	2C00107A	Wire Clamper 3B40	2
19	2B70007A	Eject /T-Close Switch SSS-13	1
20	0C09850A	Clamper Sheet	1
21	0C09830B	Carriage-S-1	1
22	0C09831B	Carriage-S-2	1
23	0C09832B	Carriage-S-3	1
24	0C09833B	Carriage-S-4	1
25	0C09834B	Carriage-S-5	1
26	0C09835B	Carriage-S-6	1
27	0C09836B	Carriage-S-7	1
28	2C00129A	Magnet 17x28.5x2	1
29	2C00130B	Clamper HI MSS	1
30	2C00127A	Clamper Plate	1
31	2B70017A	Chucking Detection Switch	1
L01	2E00036A	PT M2.6x8 + Binding (Black)	
L02	2E00038A	PT M2.6x12 + Binding	
L03	2E00032A	PT M2x6 + Binding (Black)	
L04	0E03442A	ST2.6x5 + Pan	
L05	2E00037A	PT M2.6x10 + Binding (Black)	
L06	2E00035A	PT M2.6x6 + Binding (Black)	
L07	2E00013A	M2x4 + Binding (Black)	

2.5. Tray Ass'y (B01)

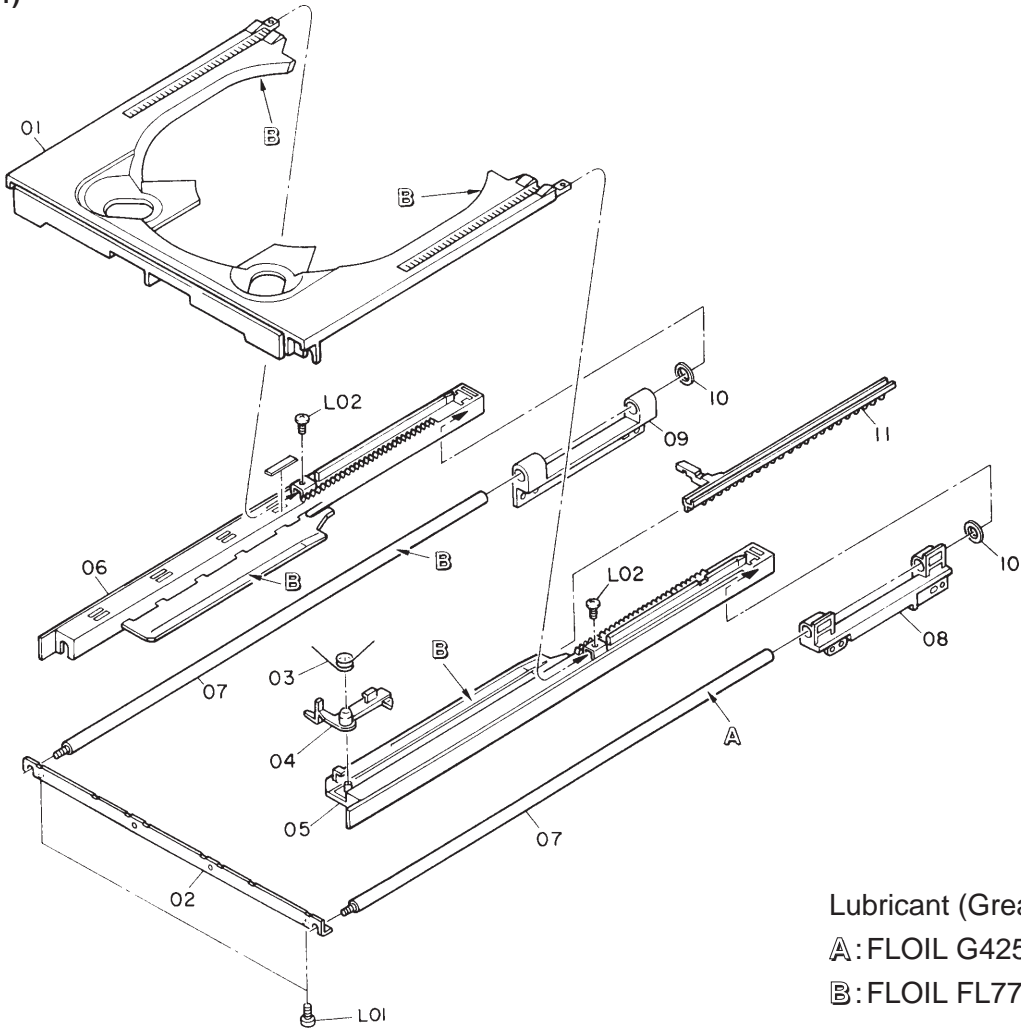

Lubricant (Grease)
 A: FLOIL G425
 B: FLOIL FL777

Fig. 2.5

2.5. Tray Ass'y (B01)

Schematic Ref. No.	Part No.	Description	Q'ty
B01	CB00246A	Tray Ass'y N	1
01	2C00287A	Tray Top N	1
02	2C00303A	Tray Plate N	1
03	2C00068A	Shuttle Lock Spring	1
04	2C00061A	Shuttle Lock	1
05	2C00291A	Tray R N	1
06	2C00290A	Tray L N	1
07	2C00302A	TR Guide Shaft N	2
08	2C00063A	Tray Guide R	1
09	2C00289A	Tray Guide L N	1
10	2C00070A	Stop Rubber	2
11	2C00286A	Shuttle N	1
L01	2E00032A	PT M2x6 + Binding (Black)	
L02	2E00029A	PT M2x4 + Binding (Black)	

2.6. Side Chassis R Section (B02)

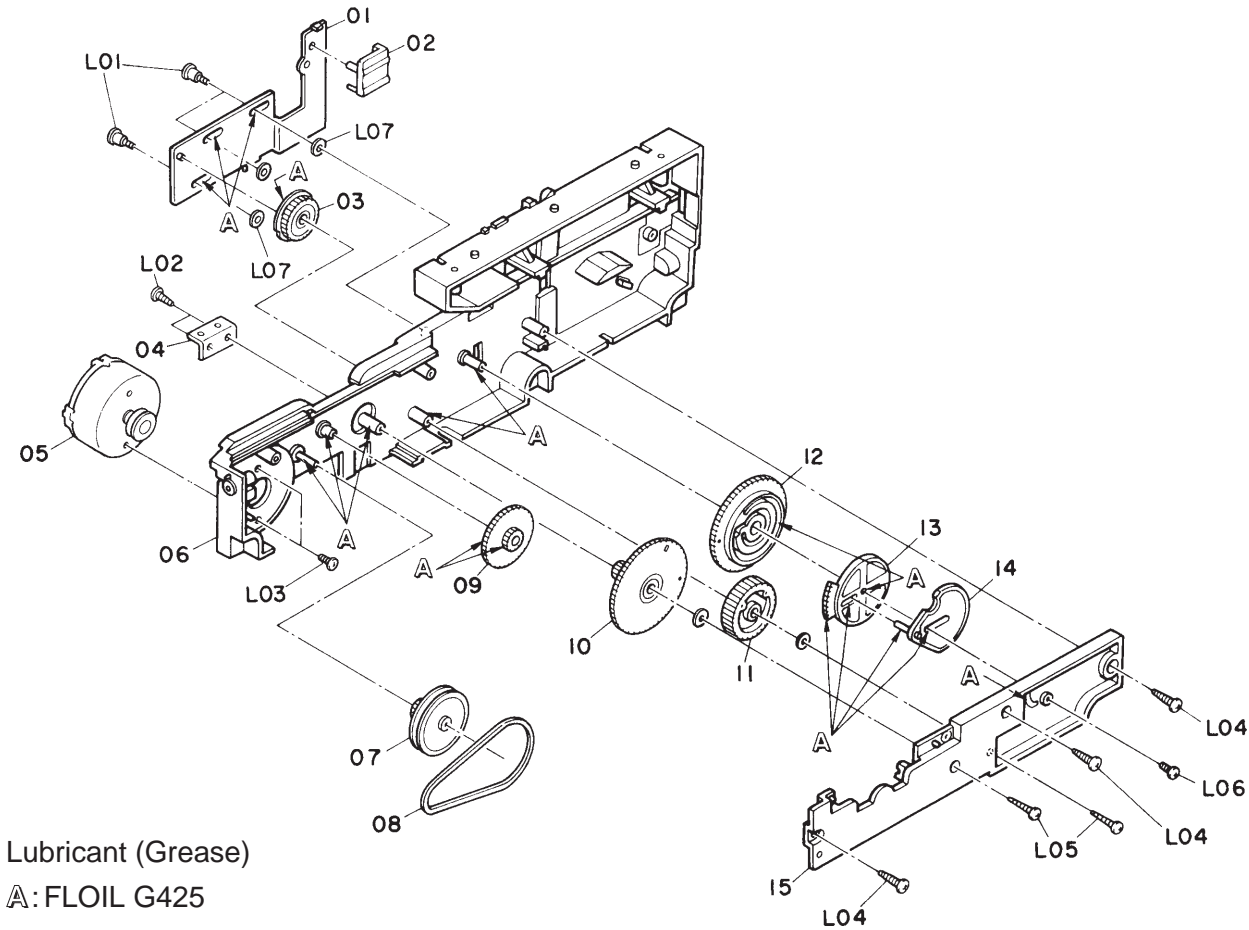

Lubricant (Grease)
A: FLOIL G425

Fig. 2.6

2.6. Side Chassis R Section (B02)

Schematic Ref. No.	Part No.	Description	Q'ty
B02	—	Side Chassis R N Section	1
01	CB00329A	Change Plate N Ass'y	1
02	2C00281A	Carriage Opener N	1
03	2C00039A	Change Gear	1
04	2C00093A	Switch Bracket	1
05	CB00216A	Loading Motor Ass'y	1
06	CB00330B	Side Chassis R Sub N Ass'y	1
07	2C00044A	S-P-Gear	1
08	2C00017A	Belt-C-S	1
09	2C00041A	Side Idler	1
10	2C00054A	S-F-Gear	1
11	2C00042A	S-I-Gear	1
12	2C00279A	S-M-Gear N	1
13	2C00280A	Tray Stopper N	1
14	CB00331A	Trace Arm N Ass'y	1
15	2C00300A	Gear Holder N	1
L01	2E00043A	PT2.0x1.2x7.2	
L02	2E00035A	PT M2.6x6 + Binding (Black)	
L03	0E00945A	M2.6x4 + Binding (Black)	
L04	2E00036A	PT M2.6x8 + Binding (Black)	
L05	2E00031A	PT M2x12 + Binding (Black)	
L06	2E00042A	M2x4 + Binding (Black)	
L07	2E00047A	Washer 2.1x5x0.5	

2.7. Main Chassis Section (B03)

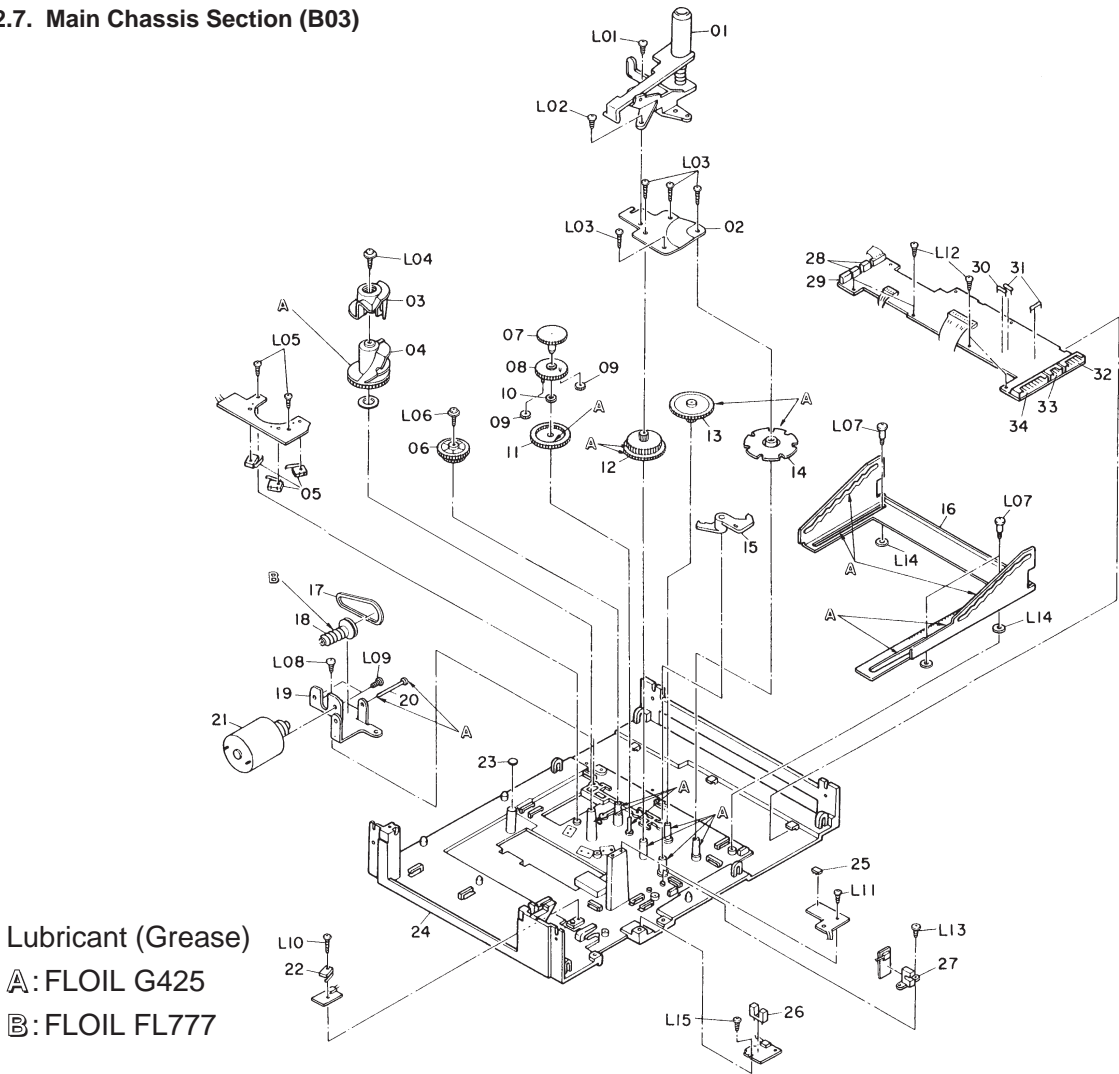

Fig. 2.7

2.7. Main Chassis Section (B03)

Schematic Ref. No.	Part No.	Description	Q'ty	Schematic Ref. No.	Part No.	Description	Q'ty
B03	—	Main Chassis N Section	1	28	0B81459A	2P T-Post	2
01	CB00335A	Disc Lock Arm N Ass'y	1	29	0B81460A	3P T-Post	1
02	2C00305A	Gear Plate	1	30	0B09663A	RK 270 1/6W J	1
03	2C00117A	ME UD Cam Top N	1	31	0B09665A	RK 330 1/6W J	2
04	2C00118A	Mecha UD Cam N	1	32	0B81470A	6P S-Post	1
05	2B70008A	Cam Switch MSS-10R2-16	3	33	0B81468A	4P S-Post	1
06	2C00082A	ID-ST-Gear	1	34	0B84475A	12P S-Post	1
07	2C00074A	D1-ST-Gear	1	L01	2E00035A	PT M2.6x6 + Binding (Black)	
08	CB00226A	D2-ST-Gear Ass'y	1	L02	0E00945A	M2.6x4 + Binding (Black)	
09	2C00075A	D3-ST-Gear	2	L03	2E00031A	PT M2x12 + Binding (Black)	
10	2C00076A	D4-ST-Gear	1	L04	2E00055A	PT M3x12 + Pan Washer-Faced	
11	2C00077A	D5-ST-Gear	1	L05	2E00040A	M1.7x5 Touchlock (Black)	
12	2C00083A	Lock Idler	1	L06	2E00009A	BT2x8 + Binding Washer-Faced	
13	2C00079A	D7M-ST-Gear	1	L07	2E00044A	PT2.6x1.4x8.9	
14	2C00278A	D6P-ST-Gear N	1	L08	2E00034A	PT M2.6x5 + Binding	
15	2C00277A	Change Arm N	1	L09	0E00501A	M3x3 + Pan	
16	2C00091A	Stocker Cam	1	L10	2E00041A	M1.7x8 Touchlock (Black)	
17	2C00018A	Belt-T-C	1	L11	2E00028A	PT M2x8 + Binding	
18	2C00092A	ST-Worm-Gear	1	L12	2E00039A	M1.7x4 Touchlock (Black)	
19	2C00088A	Motor Bracket	1	L13	2E00033A	PT M2.6x4 + Binding	
20	2C00311A	Worm Shaft N	1	L14	2E00048A	Washer 2.7x6x0.5	
21	CB00213A	Stocker Motor Ass'y	1	L15	2E00027A	PT M2x5 + Binding	
22	2B70012A	Home Position MSS-10R2-17	1	—	2B80006A	Wire CNW-W6P	1
23	2C00099A	Mecha Cushion	2	—	2B80007A	Wire CNW-2P175	1
24	CB00334B	Main Chassis N Ass'y	1	—	2B80008A	Wire CNW-2P330	1
25	0B10671A	Photoreflector GP2S40	1	—	2B80009A	Wire CNW-W4P	1
26	0B10670A	Photointerrupter GP1S52V	1	—	2B80010A	Wire CNW-W2P50	1
27	0B10669A	Photointerrupter GP1S51V	1	—	2B80011A	Wire CNW-W11P	1
				—	2B80012A	Wire CNW-3P	1

2.8. Drive Unit CA Section (B04)

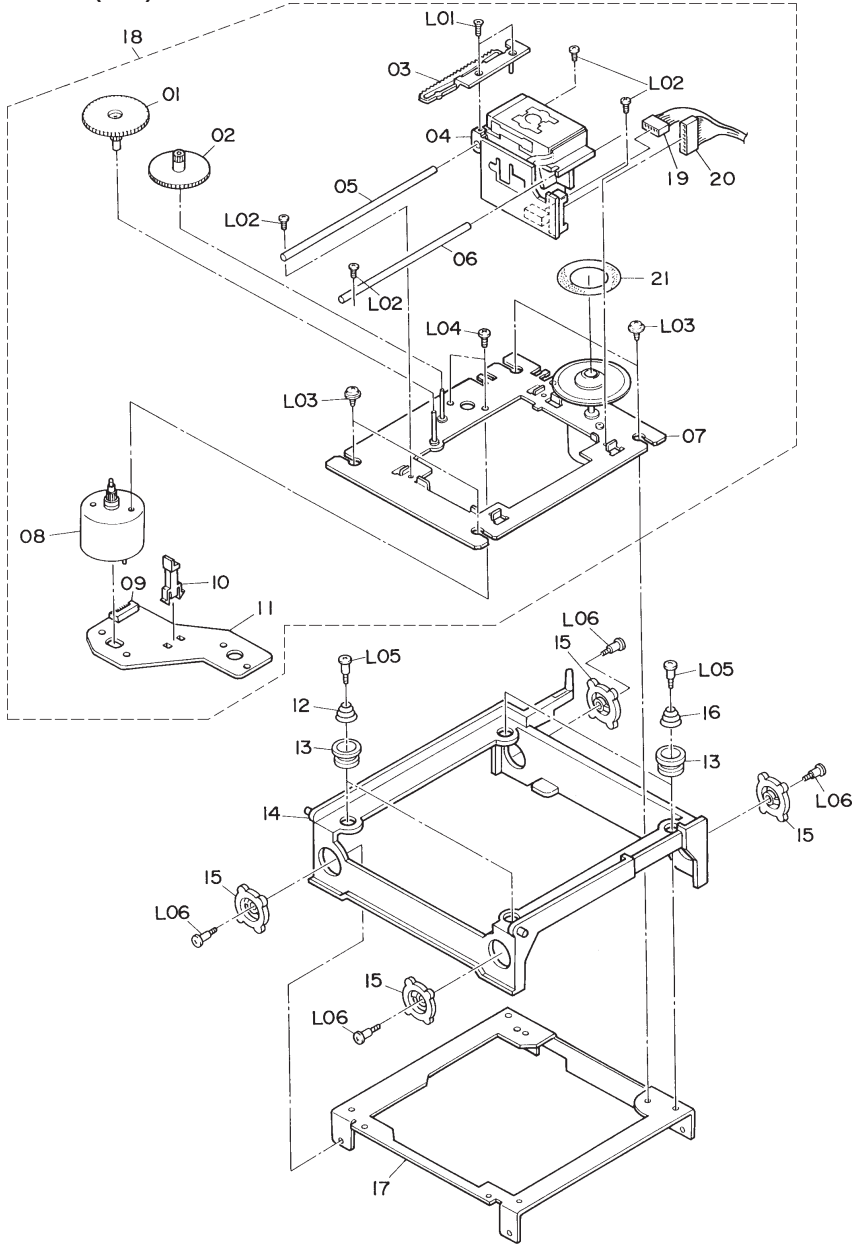

Fig. 2.8

2.8. Drive Unit CA Section (B04)

Schematic Ref. No.	Part No.	Description	Q'ty	Schematic Ref. No.	Part No.	Description	Q'ty
B04	—	Drive Unit CA Section	1	15	2C00024A	Mecha. SUS	4
01	2C00023A	Gear Power	1	16	2C00026A	Mecha. SP A	2
02	2C00022A	Gear Middle	1	17	2C00087A	Mecha. Chassis	1
03	2C00105A	Plate Rack	1	18	CB00457A	Unit Mecha Ass'y	1
04	3C09845A	Pick-up SF91PQ	1	19	2B80032A	5P Connector	1
05	2C00021A	Guide Bar B	1	20	2B80033A	8P Connector	1
06	2C00020A	Guide Bar A	1	21	2C00314A	Table Sponge	1
07	CB00458A	Disc Motor Ass'y	1	L01	0E03648A	M2x5 + Countersunk	
08	CB00218A	Feed Motor Ass'y	1	L02	2E00053A	ST M2.6x6 + Binding	
09	0B81470A	6P S-Post	1	L03	2E00054A	ST2.6x4 + Washer-Faced	
10	2B70011A	Leaf Switch BSW-333A	1	L04	0E03439A	M2x2.5 + Pan (Black)	
11	2B60002A	Motor P.C.B. 90V-M	1	L05	2E00004A	ST2.0x10x15	
12	2C00027A	Mecha. SP B	2	L06	2E00003A	ST2.0x3.0x8.0	
13	2C00025A	Mecha. Limit	4				
14	CB00332A	Mecha Base N Ass'y	1				

3. MODIFIED CIRCUIT

The following parts have been added to the **Main P.C.B. Ass'y**.

Schematic

Ref. No.	Part No.	Description	Added between
----------	----------	-------------	---------------

(Countermeasures against CD-R)

C162	0B41297A	CML 0.082 50V J	Pins 15 and 16 of U101
------	----------	-----------------	------------------------

C165	0B41975A	CC 10P 50V	Pins 8 and 9 of U101
------	----------	------------	----------------------

(Countermeasures against Cam Switch chattering)

C161	0B40111A	CE 0.47 50V	Pins 2 and 12 (GND) of CP104
------	----------	-------------	------------------------------

(Countermeasures against electric static discharge)

C166	0B41944A	CC 100P 50V K	Pins 22 and 26 (GND) of U102
------	----------	---------------	------------------------------

C167	0B41944A	CC 100P 50V K	Pins 16 and 21 (GND) of U104
------	----------	---------------	------------------------------

(Other countermeasures)

C163	0B41708A	CC 22P 50V J	In parallel with C104
------	----------	--------------	-----------------------

C164	0B41975A	CC 10P 50V D	Pins 7 and 9 of U101
------	----------	--------------	----------------------

**DRAGON-PS Limited
(Power Supply Unit)**

DRAGON-PS Limited

Power Supply Unit

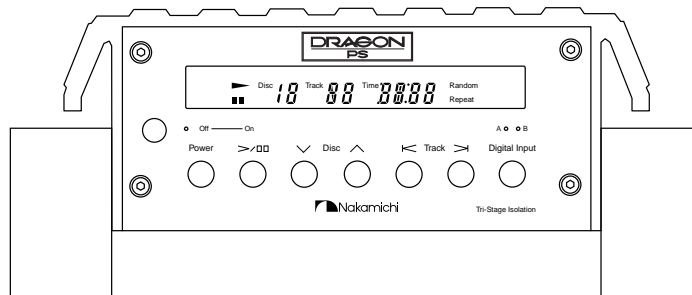

CONTENTS

1. Mechanism Ass'y and Parts List	2-2
1.1. Synthesis	2-2
1.2. Front Panel Ass'y (A01)	2-3
2. Remote Control Unit	2-4

Note:

DRAGON-PS Limited is included in the DRAGON-CD Limited. For Package Ass'y and Accessory Ass'y, refer to 1.3 "Package Ass'y and Accessory Ass'y" in the CD Player section.

1. MECHANISM ASS'Y AND PARTS LIST

1.1. Synthesis

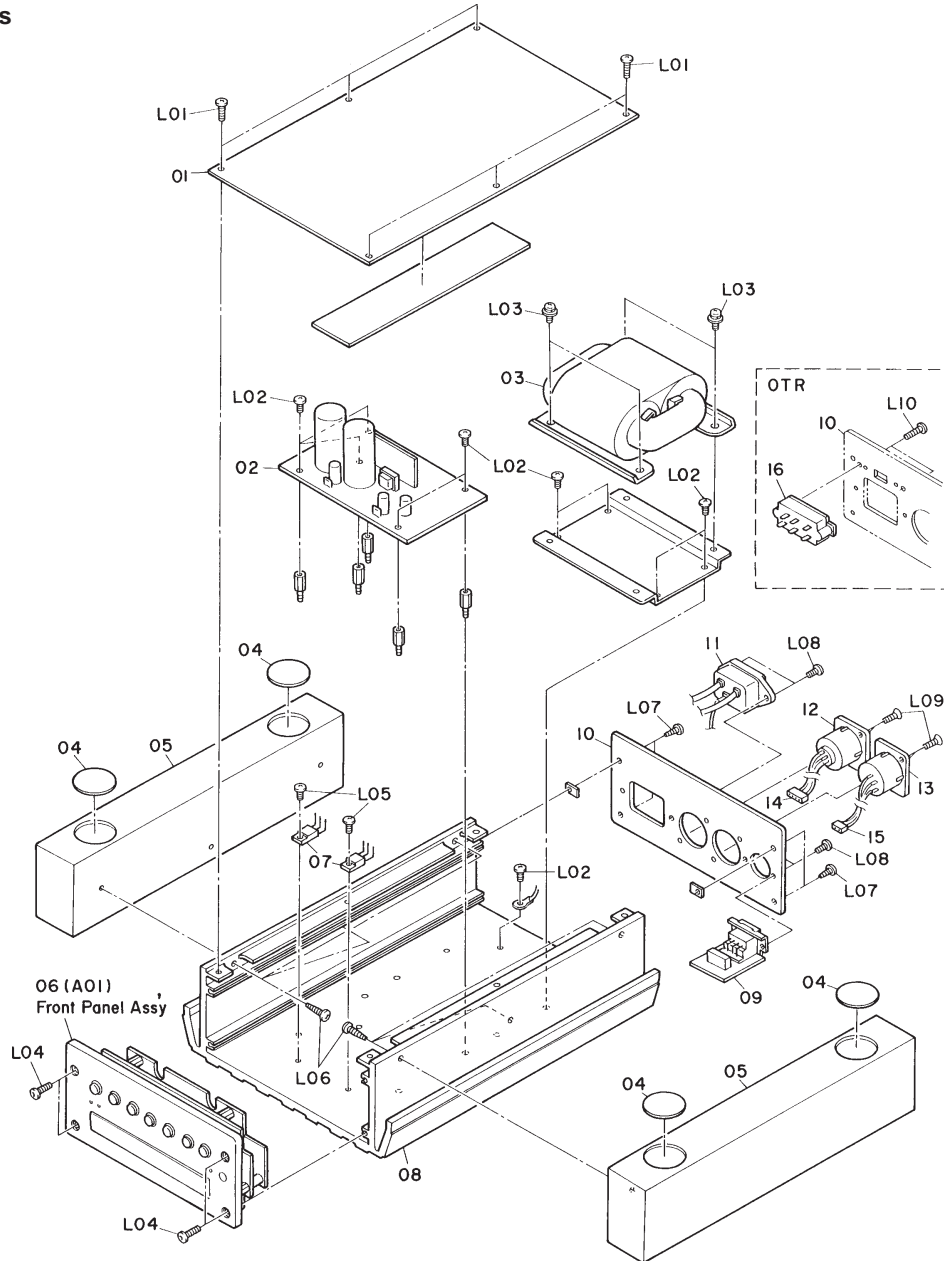

Fig. 1.1

1.1. Synthesis

Schematic Ref. No.	Part No.	Description	Q'ty	Schematic Ref. No.	Part No.	Description	Q'ty
Synthesis							
01	0H07035A	Bottom Cover	1	11	0B90092A	AC Inlet [CN701]	1
02	BA09403A	Power Supply P.C.B. Ass'y	1	12	0B80819A	4P XLR Connector (Female) [CN502]	1
03	0B50280A	Power Transformer [T701] (USA, CAN)	1	13	0B80818A	3P XLR Connector (Female) [CN501]	1
	0B50279A	Power Transformer [T701] (OTR)	1	14	0B80824A	4P Connector Ass'y [CN511]	1
	0B50278A	Power Transformer [T701] (JPN)	1	15	0B80823A	3P Connector Ass'y [CN510]	1
	0B50353A	Power Transformer [T701] (EP)	1	16	0B70242A	Voltage Selector Switch (OTR)	1
04	0J07549A	Leg Cushion	4	L01	0E03137A	M3x10 + Binding (Black)	
05	0H07032A	Side Wood Plate	2	L02	0E00964A	M3x5 + Binding	
06	—	Front Panel Assy	1	L03	0E00633A	M4x6 + Pan 3A	
07	0B10684A	IC PQ12RF2 [U701,702]	2	L04	0E04208A	M3x10 Hex. FH (Gold)	
08	0H07033A	Case	1	L05	0E00985A	M3x6 + Binding (Black)	
09	BA09404A	13 Pin Connector P.C.B. Ass'y	1	L06	0E03888A	TP3x16 + Binding Tapping	
10	0H07071A	Rear Panel (USA, CAN)	1	L07	0E00921A	BT3x8 + Binding (Black)	
	0H07047A	Rear Panel (OTR)	1	L08	0E00818A	M3x8 + Binding (Black)	
	0H08613B	Rear Panel (JPN)	1	L09	0E03905A	ST3x6 + Countersunk (Black)	
	0H08615A	Rear Panel (EP)	1	L10	0E03012A	BT3x12 + Binding (Black) (OTR)	

1.2. Front Panel Ass'y (A01)

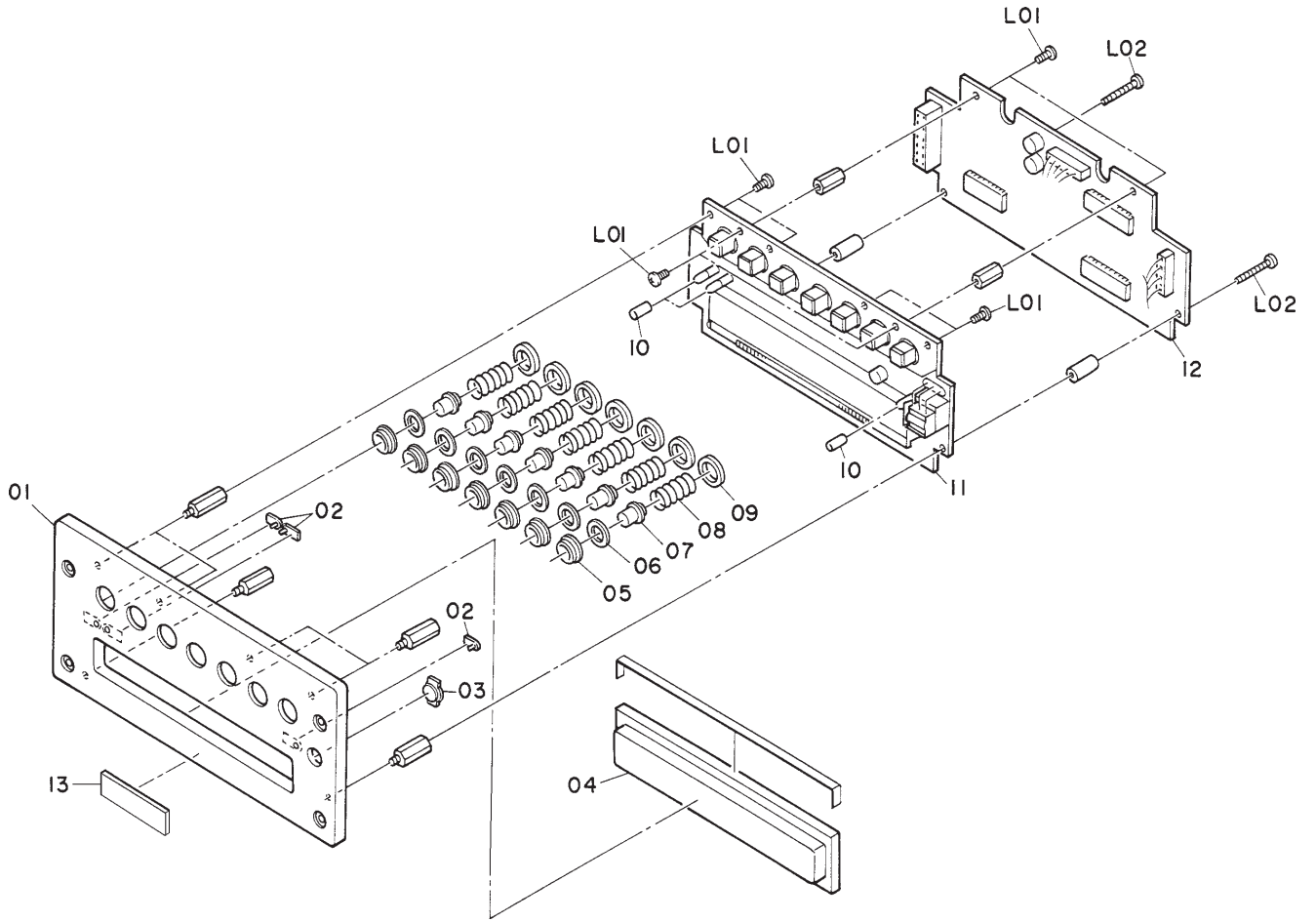

Fig. 1.2

1.2. Front Panel Ass'y (A01)

Schematic Ref. No.	Part No.	Description	Q'ty
A01	—	Front Panel Ass'y	1
01	0H08617A	Front Panel	1
02	0H05488A	LED Lens B	3
03	0H05975A	Remote Lens	1
04	0H07037A	Window	1
05	0J07552B	Sleeve	7
06	0J07554A	Cushion	7
07	0H07038A	Button	7
08	0J07553A	Spring	7
09	0J07555A	Cushion	7
10	0B80876A	Poly Tube (Black)	3
11	BA09401A	Front P.C.B. Ass'y	1
12	BA09402A	Digital P.C.B. Ass'y	1
13	0H08618A	Emblem	1
L01	0E00985A	M3x6 + Binding	
L02	0E03265A	M3x16 + Binding	

2. REMOTE CONTROL UNIT

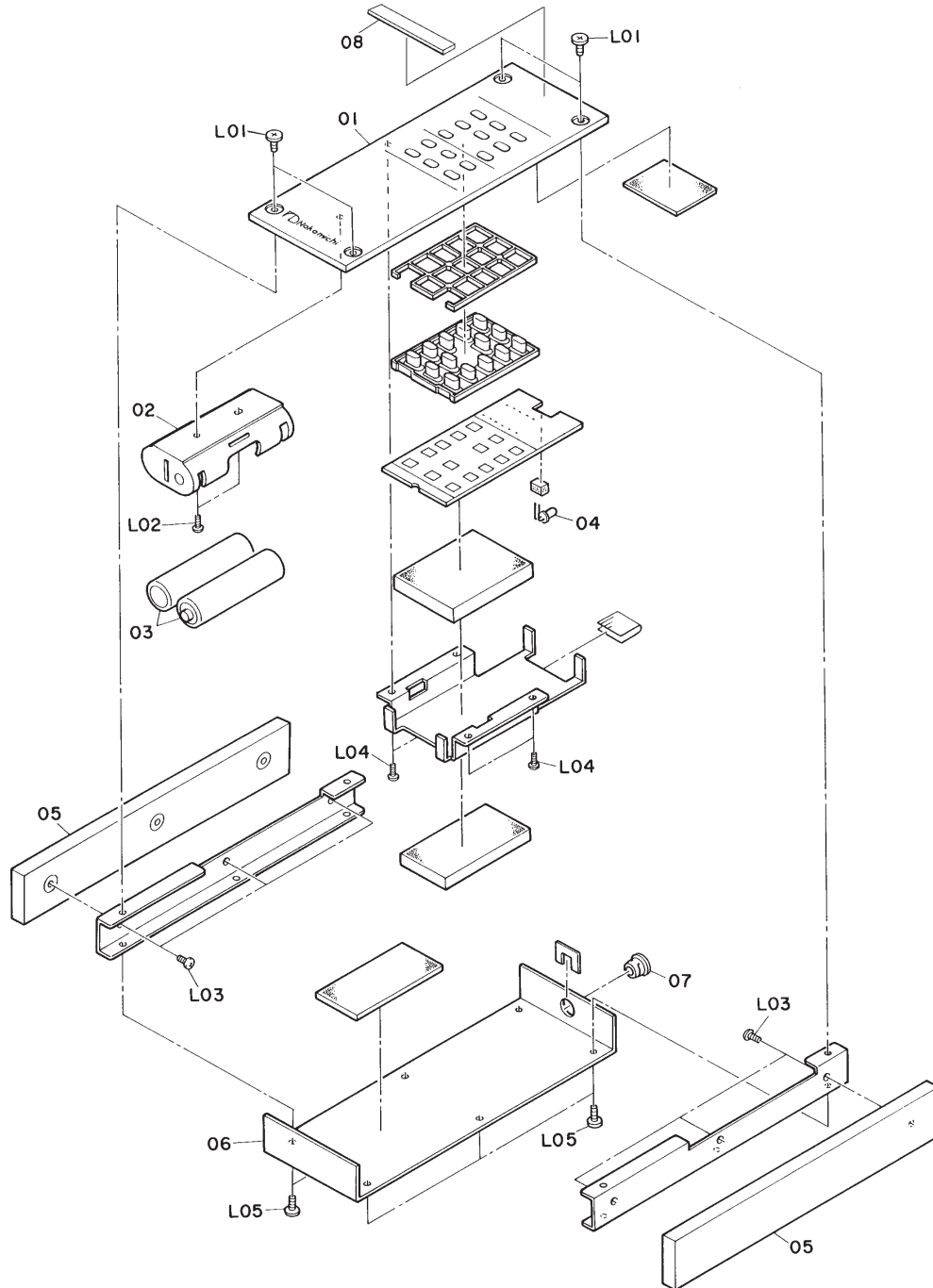

Fig. 2

Schematic Ref. No.	Part No.	Description	Q'ty	Schematic Ref. No.	Part No.	Description	Q'ty
		Remote Control Unit	1	L02	0E03691A	M2x3 + Binding (Black)	
01	0H08619A	Remote Front Panel	1	L03	0E00964A	M3x5 + Binding	
02	0B90680A	Battery Case	1	L04	0E03243A	M2x2.5 + Pan	
03	0B90683A	Battery	2	L05	0E03487A	M3x6 + Countersunk (Black)	
04	0B10909A	LED SE303A-C	1				
05	0H07041A	Remote Side Wood Plate	2				
06	0H07042A	Remote Bottom Cover	1				
07	0H07044A	Sensor Cap	1				
08	0H08622A	Emblem Remote	1				
L01	0E04209A	M3x6 + Countersunk (Gold)					



Enhanced Linearity D/A Converter

DRAGON-DAC Limited

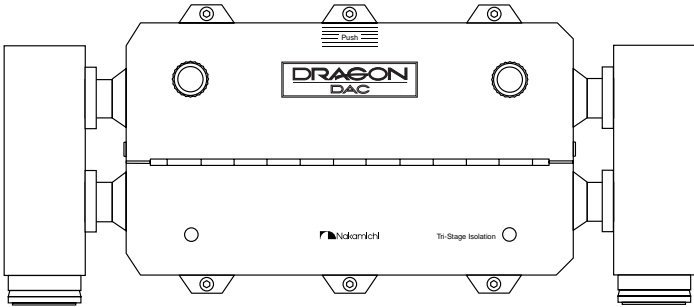

CONTENTS

- 1. General 3-2**
- 2. Parts Location for Electrical Adjustment 3-4**
- 3. Electrical Adjustments 3-4**
- 4. Mechanism Ass'y and Parts List 3-5**
 - 4.1. Synthesis 3-5
 - 4.2. Front Panel Ass'y (A01) 3-7
 - 4.3. Rear Panel Ass'y (A02) 3-8
- 5. Mounting Diagrams and Parts List 3-9**
 - 5.1. DIF D-D P.C.B. Ass'y 3-9
 - 5.2. DAC FA P.C.B. Ass'y 3-10
- 6. IC Block Diagrams 3-13**
- 7. Block Diagram 3-15**
- 8. Specifications 3-16**

Schematic Diagram for Dragon DAC Limited (See the end of this manual.)

1. GENERAL

- 1.1. Product Code**
N415

1.2. Package Ass'y and Accessory Ass'y

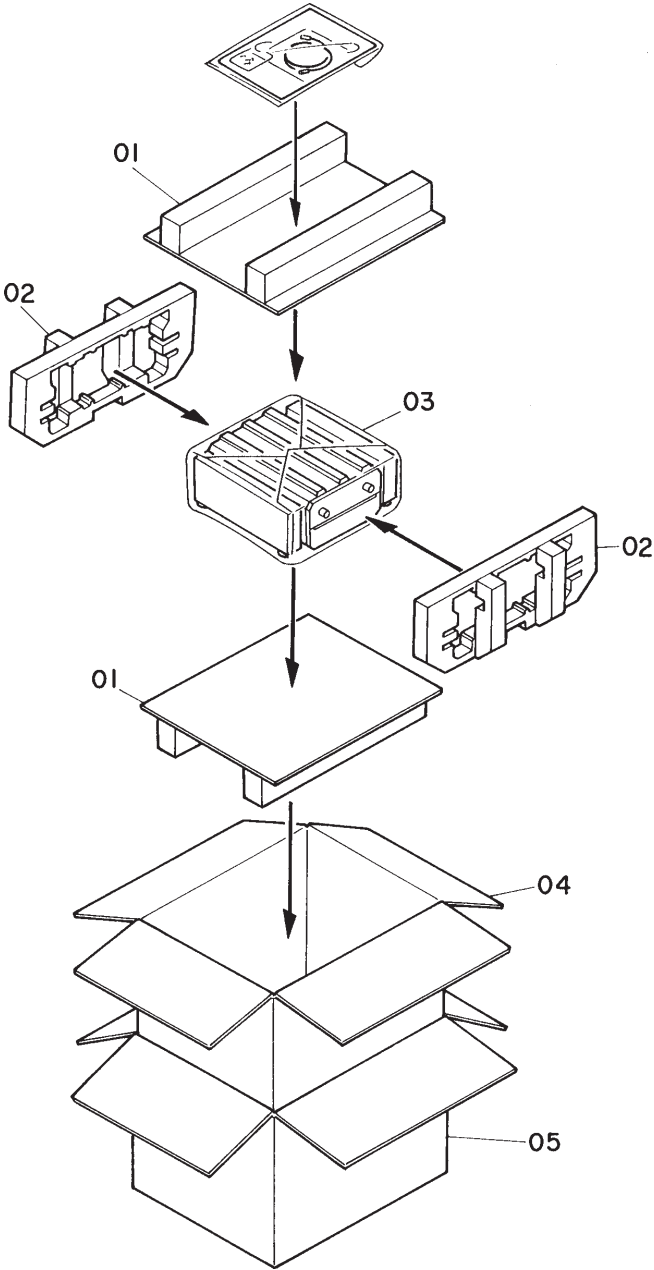
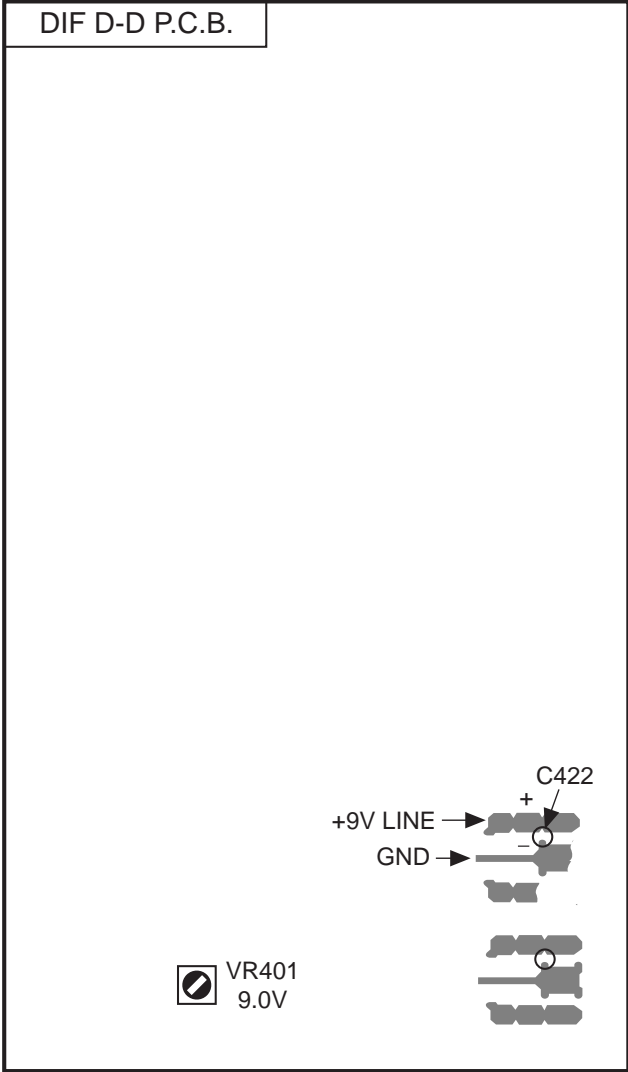

Fig. 1

Schematic Ref. No.	Part No.	Description	Q'ty	Schematic Ref. No.	Part No.	Description	Q'ty
		Package Ass'y				Accessory Ass'y	1
01	0F05022A	Spacer	2	0B80833A	Pin Pin Cable		1
02	0F05002A	Packing F,R	2	0D06704A	NC 4 Cable Ass'y		1
03	0F04956A	Soft Sheet	1	0E03310A	M4x6 + Binding (Black Chromate)		4
04	0F05004A	Inner Carton	1	0J04310A	Washer Poly Slider FT-40		4
05	0F05010A	Outer Carton	1				

2. PARTS LOCATION FOR ELECTRICAL ADJUSTMENT



[FRONT SIDE]

Fig. 2

3. ELECTRICAL ADJUSTMENTS

STEP	ITEM	OUTPUT CONNECTION	MODE	ADJUSTMENT	REMARKS
1	±9 V Adjustment	DC Voltmeter between +9 V line (+ terminal of C422) and GND (on DIF D-D P.C.B.) or between Q802L collector and GND (on DAC FA P.C.B.)	—	DIF D-D P.C.B. VR401	1. Turn ON the power. 2. Adjust VR401 to obtain +9.0 V ±0.1 V on the DC voltmeter.

4. MECHANISM ASS'Y AND PARTS LIST

4.1. Synthesis

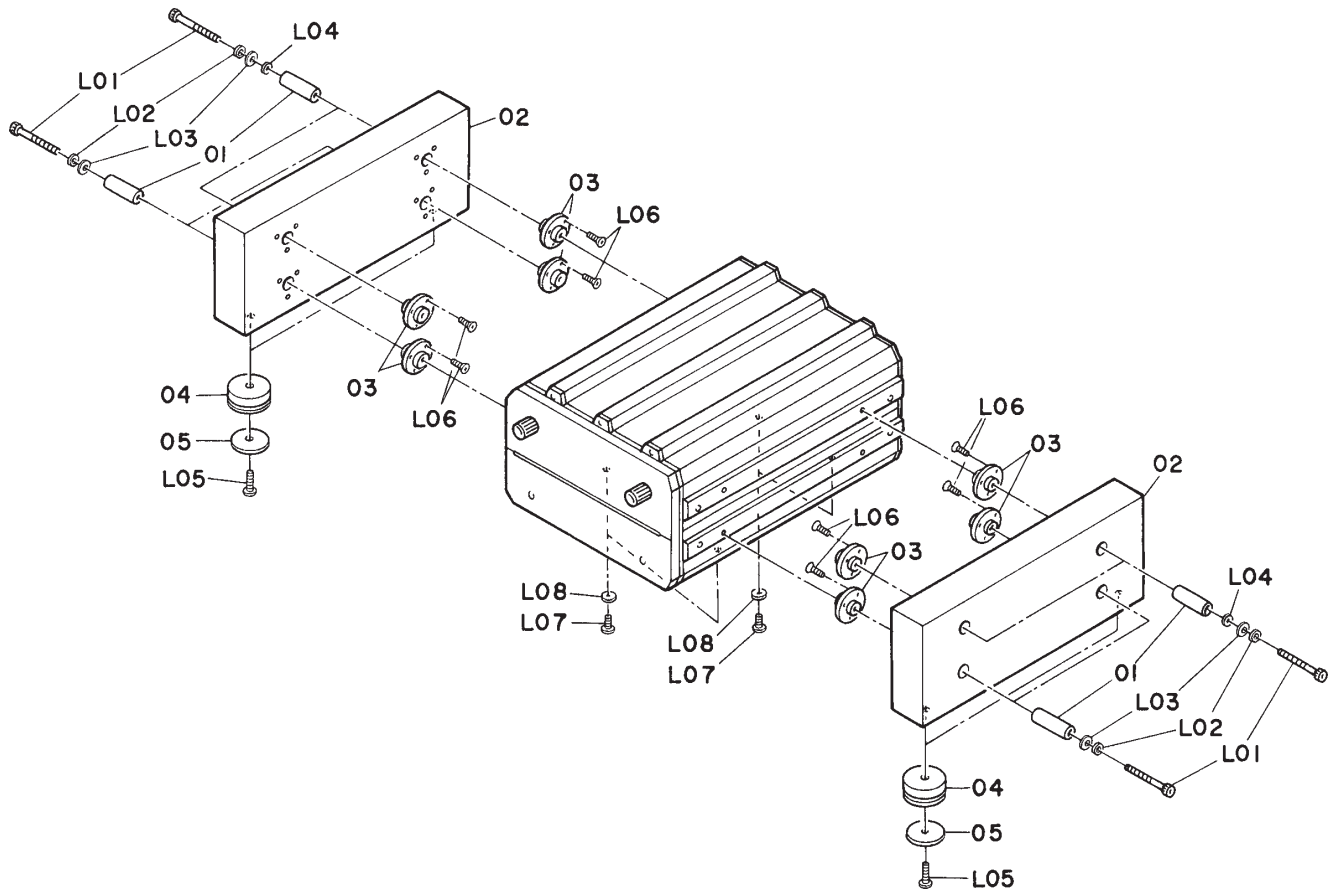

Fig. 4.1.1 Synthesis (1/2)

4.1. Synthesis

Schematic Ref. No.	Part No.	Description	Q'ty	Schematic Ref. No.	Part No.	Description	Q'ty
-	Synthesis			27	0J07601A	AI Stabilizer B	1
				28	0H07020B	Bonnet Lower	1
01	0J07542B	Sleeve	8	L01	0E03889A	M5x50 Hex. Bolt	
02	0H07021A	Side Wood Plate	2	L02	0E03883A	Washer 5.5x10x0.8 (Black)	
03	0H07024A	Side Spacer A	8	L03	0E00819A	Spring Washer 5mm	
04	0H07023A	Leg	4	L04	0J07593A	Washer Poly Slider 5mm	
05	0J07543A	Leg Cushion	4	L05	0E03872A	TP4x20 + Pan (Black)	
06	0H07014B	Bonnet Upper	1	L06	0E03901A	TP3x18 + Countersunk (Black Chromate)	
07	0J07481B	Collar	8	L07	0E03853A	Shipping Lock Screw	
08	0J07507A	AI Stabilizer	1	L08	0J04310A	Washer Poly Slider FT-40	
09	BA10267A	DAC FA P.C.B. Ass'y	1	L09	0E03866A	ST3x17 Button Bolt (Black)	
10	0J07587A	Insulating Sheet	2	L10	0E00857A	BT3x6 + Binding	
11	-	Rear Panel Ass'y	1	L11	0E03904A	M2.6x6 + Pan	
12	-	Front Panel Ass'y	1	L12	0E03902A	M2.6x6 + Binding	
13	0H07030B	Shield Plate	1	L13	0E03746A	M3x6 Countersunk	
14	0H08621A	Emblem	1	L14	0E00766A	M3x8 + Binding	
15	BA10266A	DIF D-D P.C.B. Ass'y	1	L15	0E04207A	M4x10 Button Bolt (Gold)	
16	0J07264C	Channel	2	L16	0J07594A	Washer Poly Slider 4mm	
17	3J07489A	Damper Holder F	2	L17	0E00800A	ST3x6 + Binding	
18	3J07492A	Damper SL F	2				
19	0J07538A	Damper	4				
20	0J07539B	Chassis Sub	2				
21	0J07260A	Spring Sus	4				
22	JG04906A	Main Chassis Ass'y	1				
23	0J07486A	Mecha Cushion	2				
24	3J07491A	Damper SL R	2				
25	3J07490A	Damper Holder R	2				
26	0J07456A	Seal S	2				

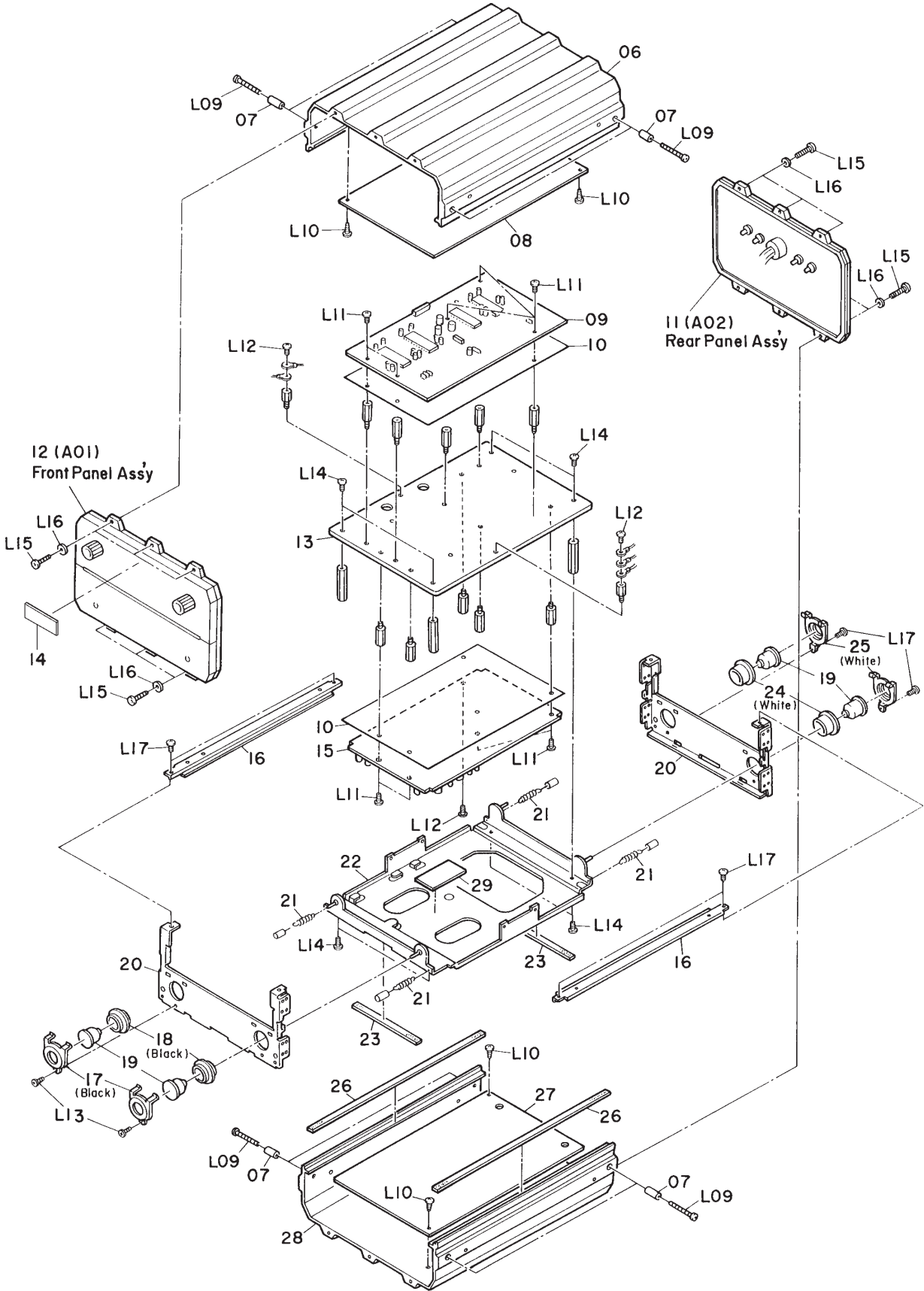

Fig. 4.1.2 Synthesis (2/2)

4.2. Front Panel Ass'y (A01)

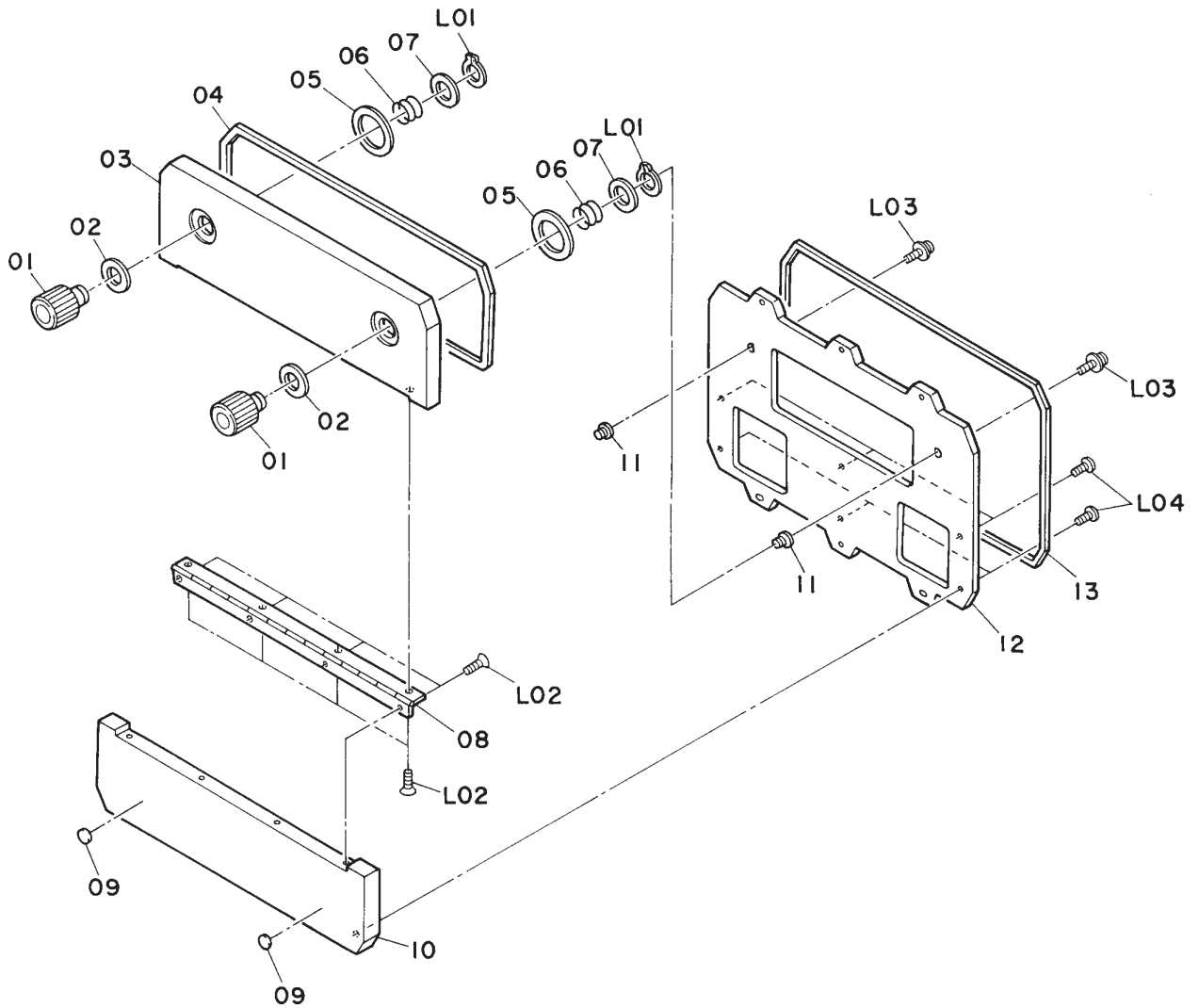

Fig. 4.2

4.2. Front Panel Ass'y (A01)

Schematic Ref. No.	Part No.	Description	Q'ty
A01	—	Front Panel Ass'y	1
01	0H08620A	Door Knob	2
02	0J07595A	Washer 12.2mm	2
03	0H08609A	Front Door	1
04	0H06935B	Door Sponge	1
05	0H07092A	Door Spacer	2
06	0J07495A	Spring K	2
07	0J07485A	Knob Spacer B	2
08	0H08607A	Door Hinge	1
09	0H06955A	Cushion D	2
10	0H07029A	Door Base	1
11	0J07484C	Lock Stud	2
12	0H07027A	Front Panel	1
13	0H07088A	Front Shield	1
L01	0E03851A	C Stopper	
L02	0E03867A	M2.6x5 + Pan Gold	
L03	0E03850A	M2.6x5 Binding + 3A	
L04	0E00896A	M3x6 + Binding	

4.3. Rear Panel Ass'y (A02)

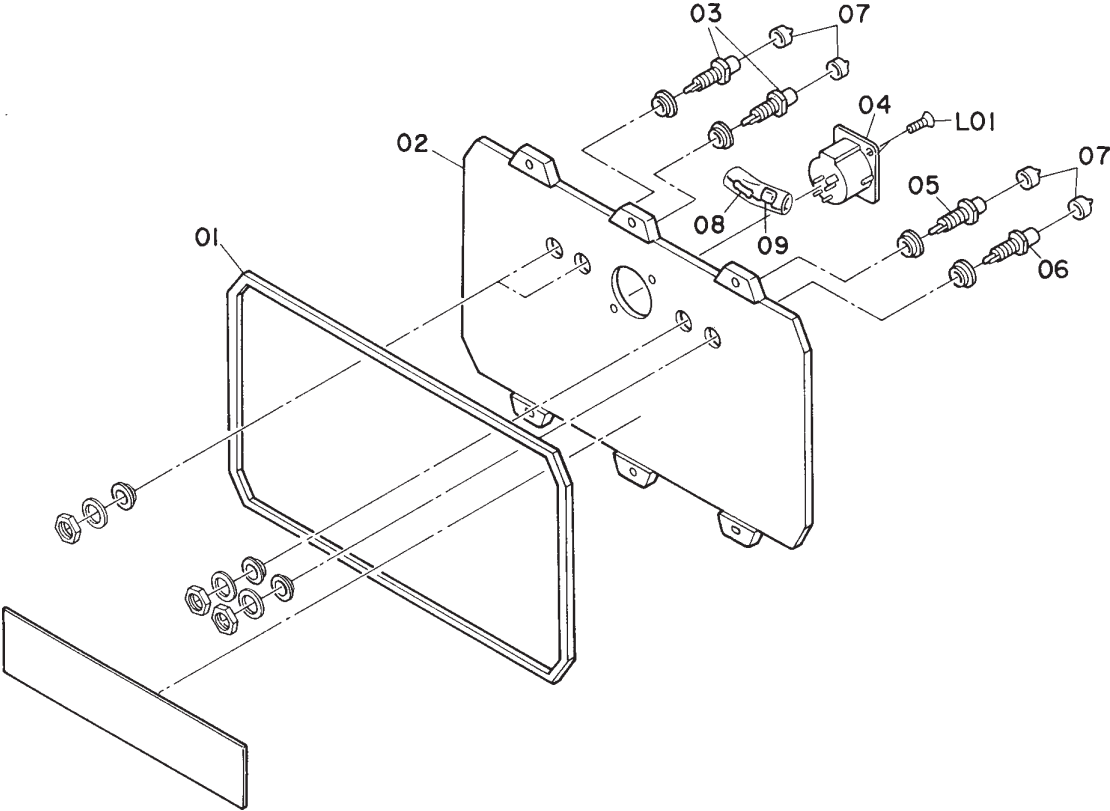

Fig. 4.3

4.3. Rear Panel Ass'y (A02)

Schematic			
Ref. No.	Part No.	Description	Q'ty
A02	—	Rear Panel Ass'y	1
01	0H07088A	Front Shield	1
02	0H07028A	Rear Panel	1
03	0B80863A	1P Pin Jack (YEL) [PJ312,313]	2
04	0B80831A	4P XLR Connector (Male) [PJ314]	1
05	0B80828A	1P Pin Jack (WHT) [PJ310]	1
06	0B80862A	1P Pin Jack (RED) [PJ311]	1
07	0B84524A	RCA Cap	4
08	0B25003A	RM 10 1/4W F [R510]	1
09	0B41823A	CML 0.01 50V J [C510]	1
L01	0E03905A	ST3x6 + Countersunk (Black Chromate)	

5. MOUNTING DIAGRAMS AND PARTS LIST

NOTE: 1. Component side is illustrated unless otherwise specified.

2. Polarity of electrolytic capacitor.



5.1. DIF D-D P.C.B. Ass'y

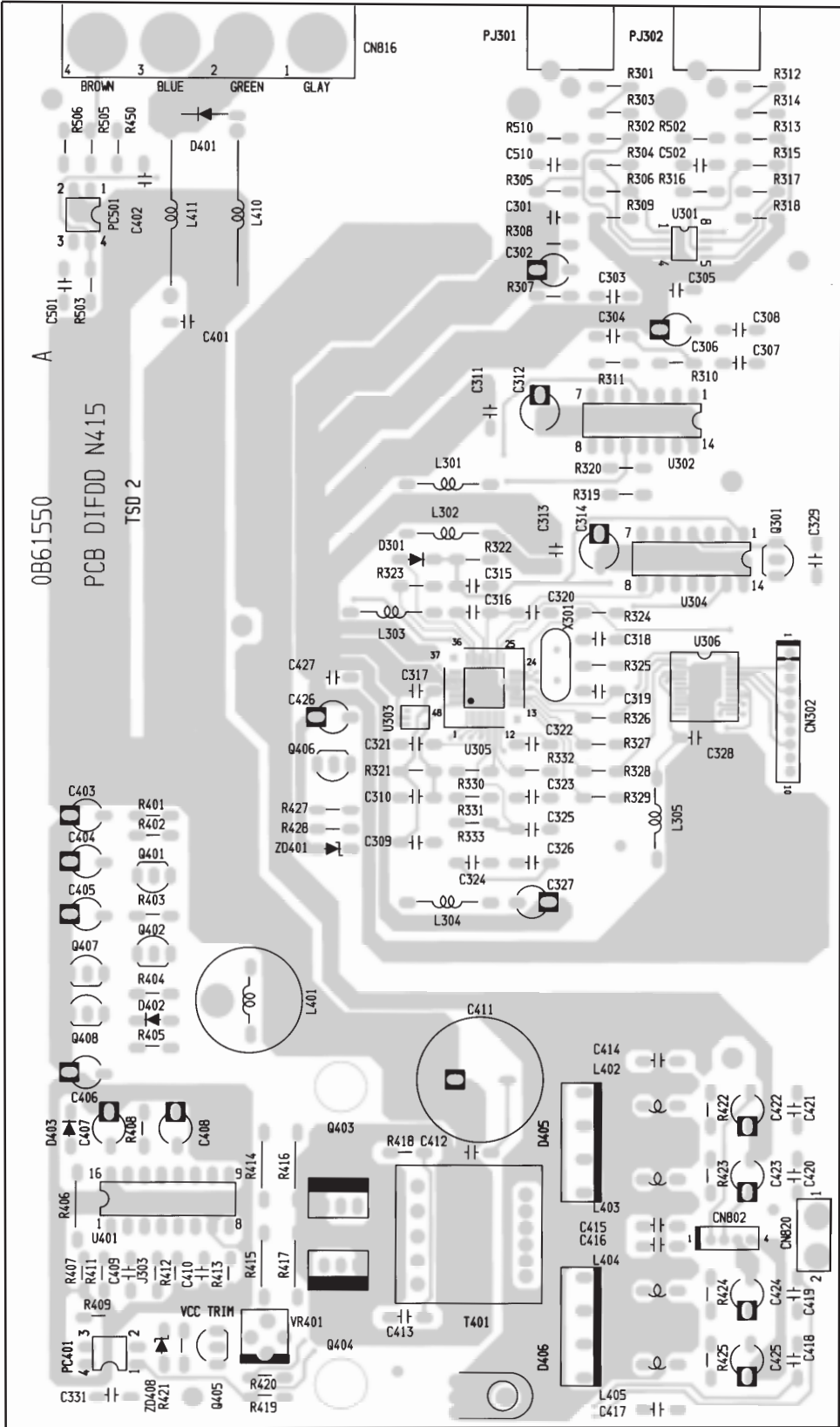

Fig. 5.1

5.2. DAC FA P.C.B. Ass'y

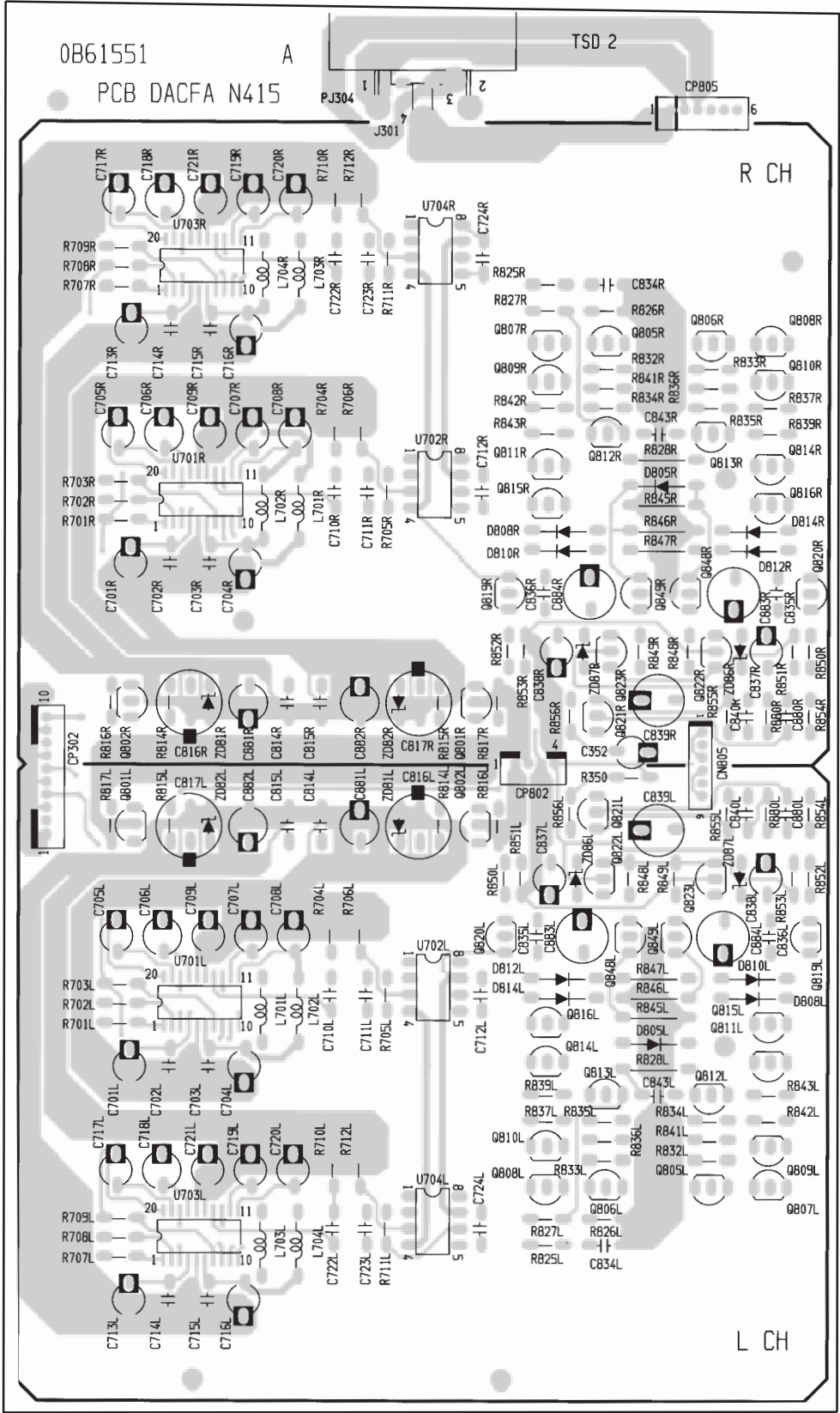

Fig. 5.2

NOTES: 1. Abbreviations

TR – Transistor, SID – Silicon Diode, ZD – Zener Diode, Varicap – Variable Capacitance Diode
 RK – Carbon Resistor, RM – Metal Film Resistor, RF – Fail Safe Type Resistor, RC – Cement Resistor
 CE – Electrolytic Capacitor, CML – Mylar Capacitor, CC – Ceramic Capacitor, CPP – PP Capacitor,
 CMM – Metalized Mylar Capacitor, CSP – Polystyrene Capacitor, C – Mica Capacitor,
 CT – Tantalum Capacitor

2. Description of capacitor: 10 16V = 10μ 16V
3. Parts marked with * show chip parts.

5.1. DIF D-D P.C.B. Ass'y

Schematic Ref. No.	Part No.	Description	Schematic Ref. No.	Part No.	Description
	BA10266A	DIF D-D P.C.B. Ass'y	R408	0B09701A	RK 10K 1/6W J
	— RCA IN —		R409	0B09656A	RK 130 1/6W J
U301	0B12933A	IC AD8058AR*	R411	0B09749A	RK 1M 1/6W J
U302	0B11568A	IC TC74HCU04AP	R412	0B09691A	RK 3.9K 1/6W J
L301	0B51040A	Micro Coil 1mH	R413	0B09701A	RK 10K 1/6W J
L306	0B51040A	Micro Coil 1mH	R414,415	0B24312R	RF 100 1/2W J
R301	0B25087A	RM 75 1/4W F	R416,417	0B24312R	RF 100 1/2W J
R302,303	0B09677A	RK 1K 1/6W J	R418	0B09661A	RK 220 1/6W J
R304,305	0B09677A	RK 1K 1/6W J	R419	0B09708A	RK 20K 1/6W J
R306	0B09677A	RK 1K 1/6W J	R420	0B09701A	RK 10K 1/6W J
R307,308	0B25669A	RM 4.7K 1/4W F	R421,422	0B09661A	RK 220 1/6W J
R309	0B09701A	RK 10K 1/6W J	R423,424	0B09661A	RK 220 1/6W J
R310	0B09717A	RK 47K 1/6W J	R425	0B09661A	RK 220 1/6W J
R311	0B25186A	RM 806 1/4W F	R450	0B09701A	RK 10K 1/6W J
R312	0B25087A	RM 75 1/4W F	C331	0B47197A	CSP 33P 160V J
R313,314	0B09677A	RK 1K 1/6W J	C401,402	0B41298A	CML 0.1 50V J
R315,316	0B09677A	RK 1K 1/6W J	C403,404	0B40559A	CE 47 16V
R317	0B09677A	RK 1K 1/6W J	C405,406	0B40650A	CE 220 16V
R318	0B09701A	RK 10K 1/6W J	C407,408	0B40050A	CE 220 6.3V
R319	0B09717A	RK 47K 1/6W J	C409	0B41273A	CPP 0.1 100V J
R320	0B25186A	RM 806 1/4W F	C410	0B05550A	CML 1000P 50V J
R502	0B25003A	RM 10 1/4W F	C411	0B40665A	CE 1000 25V
R510	0B25003A	RM 10 1/4W F	C412	0B41302A	CML 0.22 50V J
C301	0B41298A	CML 0.1 50V J	C413	0B41278A	CML 2200P 50V J
C302	0B40049A	CE 100 6.3V	C414,415	0B41274A	CML 1000P 50V J
C303	0B41273A	CPP 0.1 100V J	C416,417	0B41274A	CML 1000P 50V J
C304	0B41823A	CML 0.01 50V J	C418,419	0B41298A	CML 0.1 50V J
C305	0B41298A	CML 0.1 50V J	C420,421	0B41298A	CML 0.1 50V J
C306	0B40706A	CE 10 25V (LN)	C422,423	0B40650A	CE 220 16V
C307	0B41273A	CPP 0.1 100V J	C424,425	0B40650A	CE 220 16V
C308	0B41823A	CML 0.01 50V J	PC401	0B10336A	Photocoupler
C311	0B41298A	CML 0.1 50V J		0B80673A	Earth Terminal (1)
C312	0B40373A	CE 330 6.3V	— DIF —		
C502	0B41823A	CML 0.01 50V J	U303	0B10907A	IC PST9142NR*
C510	0B41823A	CML 0.01 50V J	U304	0B11568A	IC TC74HCU04AP
	— D-D Converter —		U305	0B12883A	IC LC89055W*
U401	0B06427A	IC UPC494C	U306	0B12828A	IC DF1704E*
Q401	0B01872A	TR 2SC945L	Q301	0B10055A	TR DTA124ES
Q402	0B06013A	TR 2SA733	Q406	0B06429A	TR 2SC2655
Q403,404	0B10343A	TR 2SC3746	ZD401	0B12150A	ZD RD5.6V JS B2
Q405	0B06142A	TR 2SC2240	D301	0B12249A	SID 1SS133
Q407	0B10070A	TR DTC143ES	L302	0B51040A	Micro Coil 1mH
Q408	0B10062A	TR DTC144ES	L303,304	0B51185A	Inductor 150uH
ZD408	0B12147A	ZD RD5.1V JS B2	L305	0B51185A	Inductor 150uH
D401	0B12362A	SID S5566B	X301	0B90755A	X'tal 12.288MHz
D402,403	0B12249A	SID 1SS133	R321,322	0B09725A	RK 100K 1/6W J
D405,406	0B12418A	SID UB-151	R323	0B09701A	RK 10K 1/6W J
T401	0B50241A	Converter Transformer	R324	0B09653A	RK 100 1/6W J
L401	0B51335A	Chooke Coil 420U 1A	R325	0B09749A	RK 1M 1/6W J
L402,403	0B51336A	Chooke Coil 470U 0.5A	R326,327	0B09653A	RK 100 1/6W J
L404,405	0B51336A	Chooke Coil 470U 0.5A	R328,329	0B09653A	RK 100 1/6W J
L410,411	0B50318A	Inductor 15uH	R330,331	0B25670A	RM 5.1K 1/4W F
VR401	0B32228A	Semi-VR 20K (B)	R332	0B25087A	RM 75 1/4W F
R401,402	0B09669A	RK 470 1/6W J	R333	0B25674A	RM 8.2K 1/4W F
R403,404	0B09693A	RK 4.7K 1/6W J	R427	0B09645A	RK 47 1/6W J
R405	0B09717A	RK 47K 1/6W J	R428	0B09651A	RK 82 1/6W J
R406	0B09314A	RK 5.1K 1/4W J	R503	0B09701A	RK 10K 1/6W J
R407	0B09694A	RK 5.1K 1/6W J	R505	0B09669A	RK 470 1/6W J
			R506	0B09701A	RK 10K 1/6W J
			C310	0B41823A	CML 0.01 50V J
			C313	0B41298A	CML 0.1 50V J

Schematic Ref. No.	Part No.	Description
C314	0B40373A	CE 330 6.3V
C315	0B41298A	CML 0.1 50V J
C316	0B40977A	CE 100 10V (LN)
C318,319	0B41708A	CC 22P 50V J
C320	0B41298A	CML 0.1 50V J
C322	0B41823A	CML 0.01 50V J
C323,324	0B41273A	CPP 0.1 100V J
C325	0B41823A	CML 0.01 50V J
C326	0B41298A	CML 0.1 50V J
C327	0B40559A	CE 47 16V
C328	0B41298A	CML 0.1 50V J
C329	0B41971A	CC 0.1 50V Z
C426	0B40707A	CE 330 10V
C427	0B41302A	CML 0.22 50V J
PC501	0B10336A	Photocoupler
— Miscellaneous —		
CN302	0B85592A	10P Connector Ass'y
CN802	0B85591A	4P Connector Ass'y
CN8161	0B85600A	Wire Gray CN816-1
CN8162	0B85601A	Wire Green CN816-2
CN8163	0B85602A	Wire Blue CN816-3
CN8164	0B85603A	Wire Brown CN816-4
CN8201	0B80850A	GND Ass'y (DA)
CN8202	0B80851A	GND Ass'y (AA)
PJ301,302	0B80846A	2P Connector Ass'y
		CN814
		0B85593A
		JW B (1)

5.2. DAC FA P.C.B. Ass'y

Schematic Ref. No.	Part No.	Description
	BA10267A	DAC FA P.C.B. Ass'y
	— DAC —	
U701L,R	0B12931A	IC PCM1704U-J*
U702L,R	0B11709A	IC NE5534AN
U703L,R	0B12931A	IC PCM1704U-J*
U704L,R	0B11709A	IC NE5534AN
Q801L,R	0B10015A	TR 2SA1020 (O,Y)
Q802L,R	0B06429A	TR 2SC2655
ZD81L	0B12150A	ZD RD5.6V JS B2
ZD81R	0B12150A	ZD RD5.6V JS B2
ZD82L	0B12150A	ZD RD5.6V JS B2
ZD82R	0B12150A	ZD RD5.6V JS B2
L701L,R	0B51114A	Inductor Micro Coil 10
L702L,R	0B51114A	Inductor Micro Coil 10
L703L,R	0B51114A	Inductor Micro Coil 10
L704L,R	0B51114A	Inductor Micro Coil 10
R701L,R	0B01679A	RK 100 1/4W J
R702L,R	0B01679A	RK 100 1/4W J
R703L,R	0B01679A	RK 100 1/4W J
R704L,R	0B25205A	RM 1.27K 1/4W F
R705L,R	0B25234A	RM 2.55K 1/4W F
R706L,R	0B25181A	RM 715 1/4W F
R707L,R	0B01679A	RK 100 1/4W J
R708L,R	0B01679A	RK 100 1/4W J
R709L,R	0B01679A	RK 100 1/4W J

Schematic Ref. No.	Part No.	Description
R710L,R	0B25205A	RM 1.27K 1/4W F
R711L,R	0B25234A	RM 2.55K 1/4W F
R712L,R	0B25181A	RM 715 1/4W F
R814L,R	0B09645A	RK 47 1/6W J
R815L,R	0B09645A	RK 47 1/6W J
R816L,R	0B09651A	RK 82 1/6W J
R817L,R	0B09651A	RK 82 1/6W J
C701L,R	0B40986A	CE 47 10V (LN)
C702L,R	0B47197A	CSP 33P 160V J
C703L,R	0B47197A	CSP 33P 160V J
C704L,R	0B40986A	CE 47 10V (LN)
C705L,R	0B40657A	CE 22 25V (LN)
C706L,R	0B40977A	CE 100 10V (LN)
C707L,R	0B40986A	CE 47 10V (LN)
C708L,R	0B40986A	CE 47 10V (LN)
C709L,R	0B40986A	CE 47 10V (LN)
C710L,R	0B41772A	CSP 1000P 160V J
C711L,R	0B41772A	CSP 1000P 160V J
C712L,R	0B47197A	CSP 33P 160V J
C713L,R	0B40986A	CE 47 10V (LN)
C714L,R	0B47197A	CSP 33P 160V J
C715L,R	0B47197A	CSP 33P 160V J
C716L,R	0B40986A	CE 47 10V (LN)
C717L,R	0B40657A	CE 22 25V (LN)
C718L,R	0B40977A	CE 100 10V (LN)
C719L,R	0B40986A	CE 47 10V (LN)
C720L,R	0B40986A	CE 47 10V (LN)
C721L,R	0B40986A	CE 47 10V (LN)
C722L,R	0B41772A	CSP 1000P 160V J
C723L,R	0B41772A	CSP 1000P 160V J
C724L,R	0B47197A	CSP 33P 160V J
C814L,R	0B47197A	CSP 33P 160V J
C815L,R	0B47197A	CSP 33P 160V J
C816L,R	0B40714A	CE 330 10V (LN)
C817L,R	0B40714A	CE 330 10V (LN)
C881L,R	0B42132A	CE 100 10V (LN)
C882L,R	0B42132A	CE 100 10V (LN)
CP302	0B84085A	10P T-Post

— FAMP —

Q805L,R	0B06180A	TR 2SA970
Q806L,R	0B06142A	TR 2SC2240
Q807L,R	0B06180A	TR 2SA970
Q808L,R	0B06142A	TR 2SC2240
Q809L,R	0B06142A	TR 2SC2240
Q810L,R	0B06180A	TR 2SA970
Q811L,R	0B06142A	TR 2SC2240
Q812L,R	0B06180A	TR 2SA970
Q813L,R	0B06142A	TR 2SC2240
Q814L,R	0B06180A	TR 2SA970
Q815L,R	0B06142A	TR 2SC2240
Q816L,R	0B06180A	TR 2SA970
Q819L,R	0B06180A	TR 2SA970
Q820L,R	0B06142A	TR 2SC2240
Q821L,R	0B06299A	TR 2SC2878
Q822L,R	0B06180A	TR 2SA970
Q823L,R	0B06142A	TR 2SC2240
Q848L,R	0B06142A	TR 2SC2240
Q849L,R	0B06180A	TR 2SA970
ZD86L	0B12159A	ZD RD7.5V JS B2
ZD86R	0B12159A	ZD RD7.5V JS B2
ZD87L	0B12159A	ZD RD7.5V JS B2
ZD87R	0B12159A	ZD RD7.5V JS B2
D805L,R	0B12635A	Varistor (SV03YS)
D808L,R	0B12634A	S Varistor 02YS
D810L,R	0B12634A	S Varistor 02YS
D812L,R	0B12634A	S Varistor 02YS
D814L,R	0B12634A	S Varistor 02YS
R350	0B09725A	RK 100K 1/6W J
R825L,R	0B25664A	RM 3K 1/4W F
R826L,R	0B22644A	RM 1.54K 1/4W F
R827L,R	0B25664A	RM 3K 1/4W F
R828L,R	0B22644A	RM 1.54K 1/4W F
R832L,R	0B25107A	RM 121 1/4W F

Schematic Ref. No.	Part No.	Description
R833L,R	0B25107A	RM 121 1/4W F
R834L,R	0B25107A	RM 121 1/4W F
R835L,R	0B25107A	RM 121 1/4W F
R836L,R	0B25171A	RM 562 1/4W F
R837L,R	0B25116A	RM 150 1/4W F
R839L,R	0B25087A	RM 75 1/4W F
R841L,R	0B25171A	RM 562 1/4W F
R842L,R	0B25116A	RM 150 1/4W F
R843L,R	0B25087A	RM 75 1/4W F
R845L,R	0B09595A	RM 56.2K 1/4W F
R846L,R	0B09595A	RM 56.2K 1/4W F
R847L,R	0B09203A	RM 10K 1/4W F
R848L,R	0B25053A	RM 33.2 1/4W F
R849L,R	0B25053A	RM 33.2 1/4W F
R850L,R	0B09645A	RK 47 1/6W J
R851L,R	0B09653A	RK 100 1/6W J
R852L,R	0B09645A	RK 47 1/6W J
R853L,R	0B09653A	RK 100 1/6W J
R854L,R	0B25356A	RM 47.5K 1/4W F
R855L,R	0B22567A	RM 100 1/4W F
R856L,R	0B09693A	RK 4.7K 1/6W J
R880L,R	0B25191A	RM 909 1/4W F
R881L,R	0B22762A	RM 8.2 1/4W F
C352	0B40756A	CE 1 50V (LN)
C834L,R	0B41129A	CPP 1500P 100V G
C835L,R	0B47290A	CSP 51P 160V J
C836L,R	0B47290A	CSP 51P 160V J
C837L,R	0B40678A	CE 220 10V (LN)
C838L,R	0B40678A	CE 220 10V (LN)
C839L,R	0B42131A	CE 47 50V (LN)
C840L,R	0B47290A	CSP 51P 160V J
C843L,R	0B41129A	CPP 1500P 100V G
C880L,R	0B41135A	CPP 2700P 100V G
C883L,R	0B42136A	CE 220 10V (LN)
C884L,R	0B42136A	CE 220 10V (LN)
CP802	0B81461A	4P T-Post

— Miscellaneous —

CN805	0B80842A	6P Connector Ass'y CN810
CN821	0B80853A	GND Ass'y (AC)
CN822	0B80854A	GND Ass'y (DB)

6. IC BLOCK DIAGRAMS

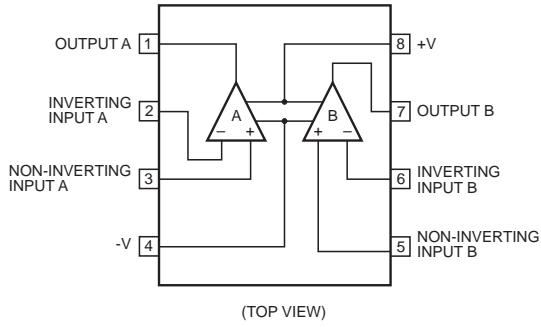

Fig. 6.1 Operational Amp. AD8058AR

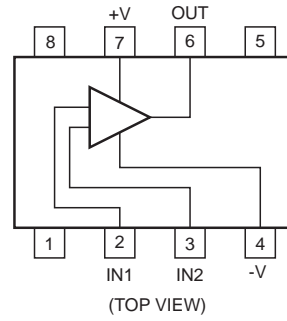

Fig. 6.2 Operational Amp. NE5534AN

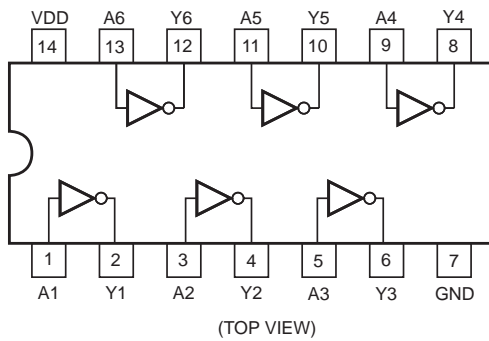

Fig. 6.3 Inverter TC74HCU04AP (U302, 304)

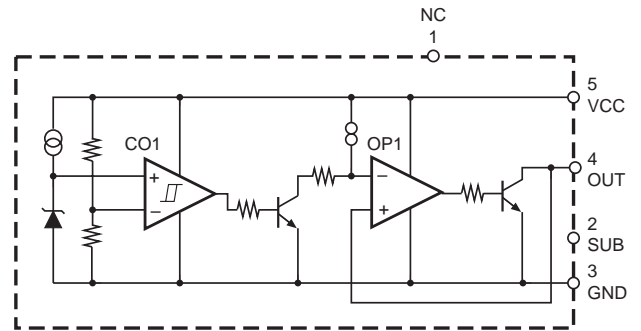

Fig. 6.4 Voltage Detector PST9142NR (U303)

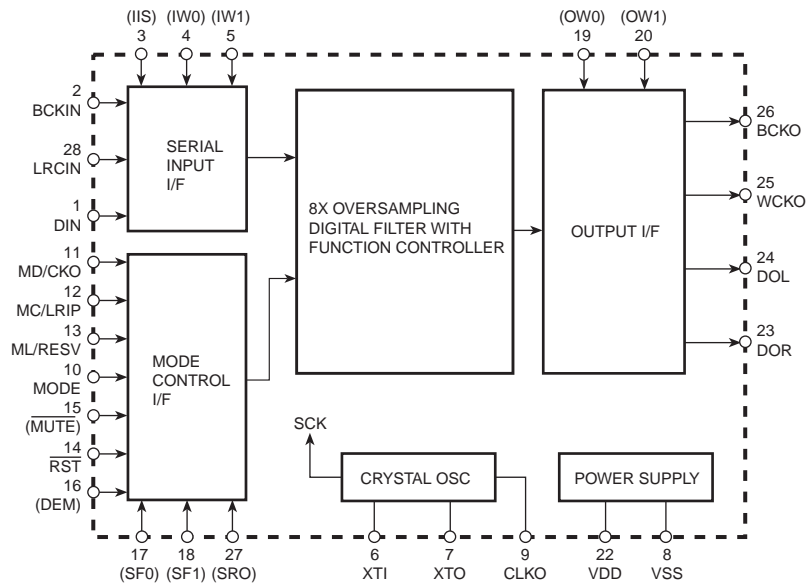

Fig. 6.5 8-Times Oversampling Digital Filter DF1704E (U306)

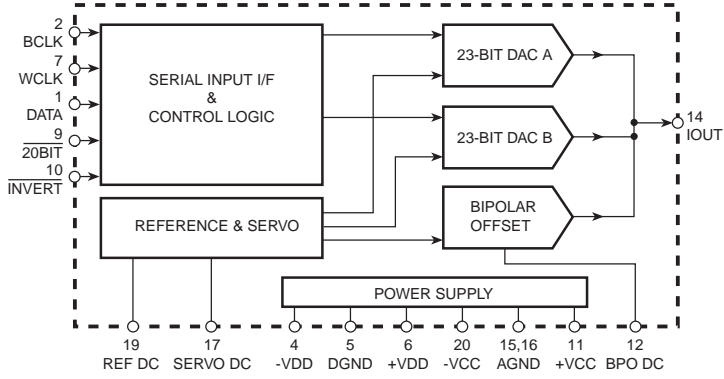

Fig. 6.6 24-Bit D/A Converter PCM1704U (U701L/R, U703L/R)

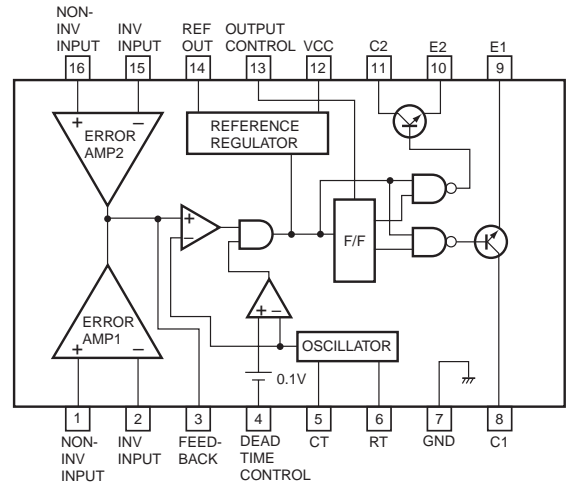

Fig. 6.7 Protector μPC494 (U401)

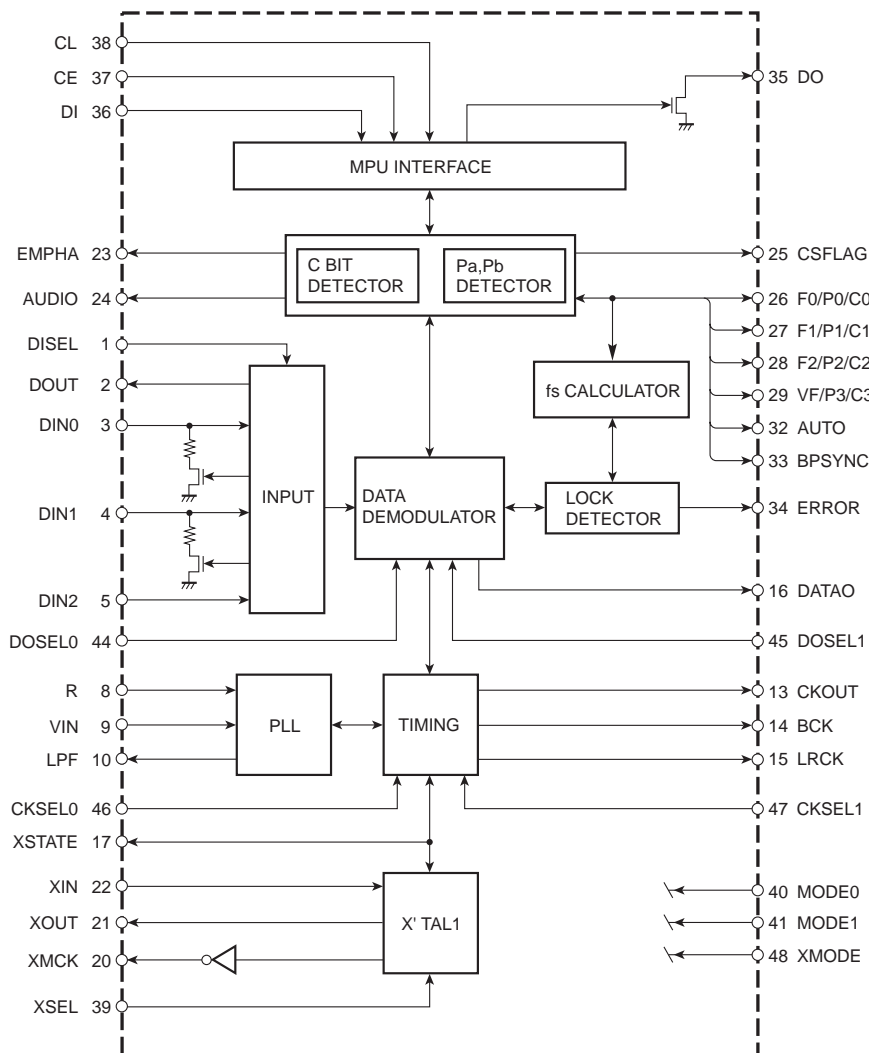

Fig. 6.8 Digital Audio Interface Receiver LC89055W (U305)

7. BLOCK DIAGRAM

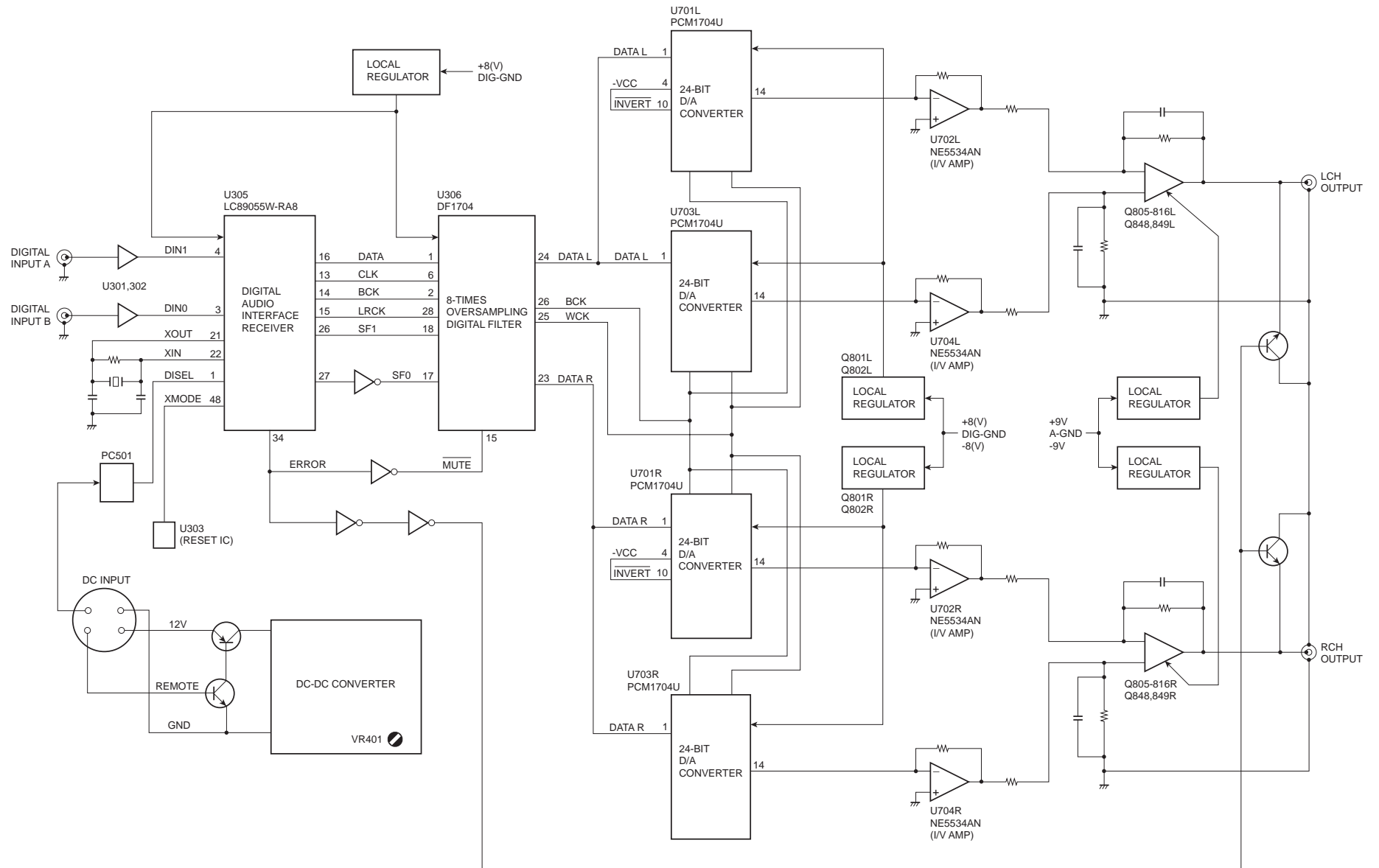

Fig. 7

8. SPECIFICATIONS

[DRAGON-DAC Limited]

Digital Input (Coaxial)

Input Impedance 75 Ω

Input Level 0.5 Vp-p

Sampling Frequency 44.1 kHz/48 kHz/96 kHz (Automatic Selection)

Outputs

Line Output Level 1 kHz, 0dB 2.0 V \pm 1.0 dB

Channel Balance Within 0.5 dB

Total Harmonic Distortion (THD + Noise)

1 kHz, 0 dB Less than 0.003% (20 kHz LPF)

Frequency Response

20 Hz - 20 kHz Within 0 dB, -1.0 dB

Channel Balance Within 0.5 dB

Channel Separation

1 kHz, 0 dB More than 100 dB (20 kHz LPF)

Signal to Noise Ratio

1 kHz, 0 dB More than 100 dB (20 kHz LPF, IHF-A)

Dynamic Range

1 kHz, 0 dB More than 98 dB (20 kHz LPF, IHF-A)

De-emphasis

16 kHz -9.04 dB \pm 0.8 dB

Dimensions* 321(W) \times 148 (H) \times 299 (D) mm

12-5/8(W) \times 5-13/16 (H) \times 11-3/4 (D) inches

Approximate Weight 8.0 kg/17 lbs. 10 oz.

*: Dimensions do not include protruding parts. Height is the panel height without feet.

• Specifications and design are subject to change for further improvement without notice.

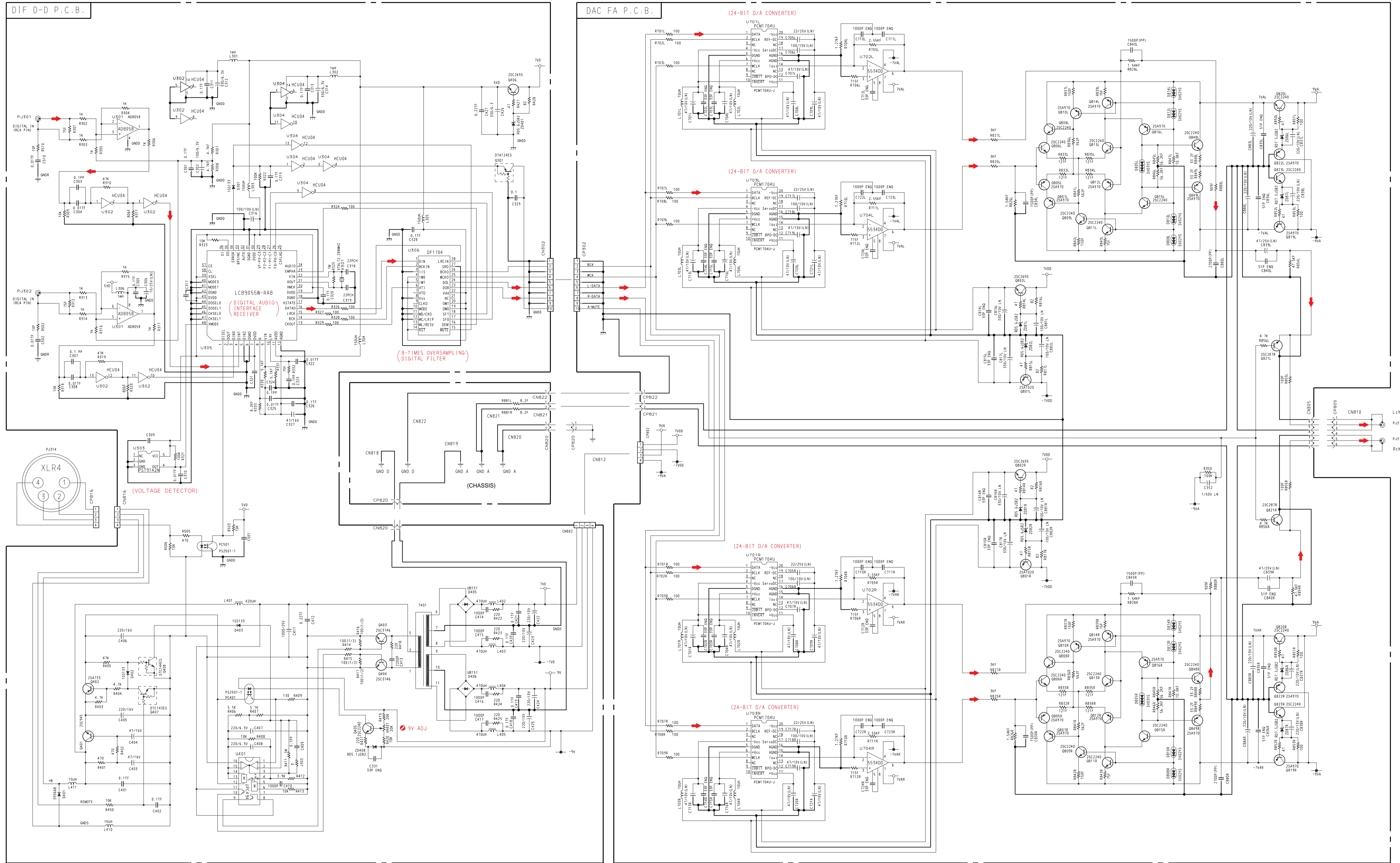

NOTE : Description of electrolytic capacitor : 100/16V=100 16V

Nakamichi Corporation	1-153 Suzukicho, Kodaira, Tokyo 187-8501, Japan Phone: 81 (42) 342-1111
Nakamichi America	955 Francisco St., Torrance, CA 90502 Phone: 1 (310) 538-8150 Fax: 1 (310) 324-7614
Nakamichi Asia	8/F The Grande Bldg., 398 Kwun Tong Rd., Kowloon, Hong Kong Phone: 852-2357-6690 Fax: 852 -2357-6697
Nakamichi Europe	8th Floor, Hayes Gate House, 27 Uxbridge Road Hayes, Middlesex, UB4 OJN, England Phone: 44-181-581-9191 Fax: 44-181-581-9153
Web Site	http://www.nakamichi.com